

SEAT ASSEMBLIES 3M

SECTION INDEX

	Page		Page
Carpeting	3M-9	Power Seats	3M-6
Front Seats	3M-1	Tools	3M-9
Rear Seats	3M-5		

FRONT SEATS

	Page		Page
Cherokee-Wagoneer-Truck Bench Seats	3M-3	CJ and Scrambler Floor Console	3M-4
Cherokee-Wagoneer-Truck Bucket Seats	3M-3	General	3M-1
CJ and Scrambler Bucket Seats	3M-1	Seat Belts	3M-4

GENERAL

Bucket seats are standard on CJ, Scrambler and Cherokee 2-door models (fig. 3M-1) and optional on the Wagoneer, 4-door Cherokee, and Truck models. The passenger side bucket seat, except CJ, is adjustable fore and aft. On Cherokee 2-door models, the passenger side bucket seat has a forward tilting seat back for access to rear seat or tool storage area. On truck models, both passenger and driver seat backs are forward tilting. A folding support for passenger side bucket seat on CJ and Scrambler models allows the whole seat to move forward for easier entry to the rear area. CJ-7 Limited models equipped with highback bucket seats have a folding support on the driver's seat also.

On all Truck models, the bench seat back swings forward for access to the seat back storage area. The seat back locks automatically in the fully upright position to prevent it from tilting forward in the event of sudden stops. To release the seat back lock, pull up on the seat back release.

The fore-and-aft seat adjuster mechanism for Cherokee-Wagoneer-Truck models and left front CJ and Scrambler seats has a turnbuckle to allow for slight dimensional variances during production assembly of seats and seat support components. The turnbuckle permits the seat sliding and latching components to be adjusted for trouble-free operation. Adjustment of the turnbuckle is covered in this chapter.

All seat belts utilize quick-release buckle latches. Cherokee and Wagoneer models are equipped with three sets of rear seat belts; the two outboard seat belt retractors are anchored on the wheelhousings.

CJ AND SCRAMBLER BUCKET SEATS

The seats are removed by unfastening the supports and braces from the floorpan.

The left front seat frame attaches to the seat slides and the seat slides, in turn, attach to braces or supports which are fastened to the floorpan. The seat may be locked in the full forward position, or every half inch toward the full rear position, for a distance of approximately 2-1/2 inches on CJ-5 models and five inches on other models.

Removal

- (1) Remove screws (fig. 3M-1) attaching supports and braces to floorpan.
- (2) Remove seat assembly from vehicle.

Installation

- (1) Position seat assembly in vehicle.
- (2) Install screws attaching supports and braces to floorpan. Tighten screws to 15 foot-pounds (20 N•m) torque.

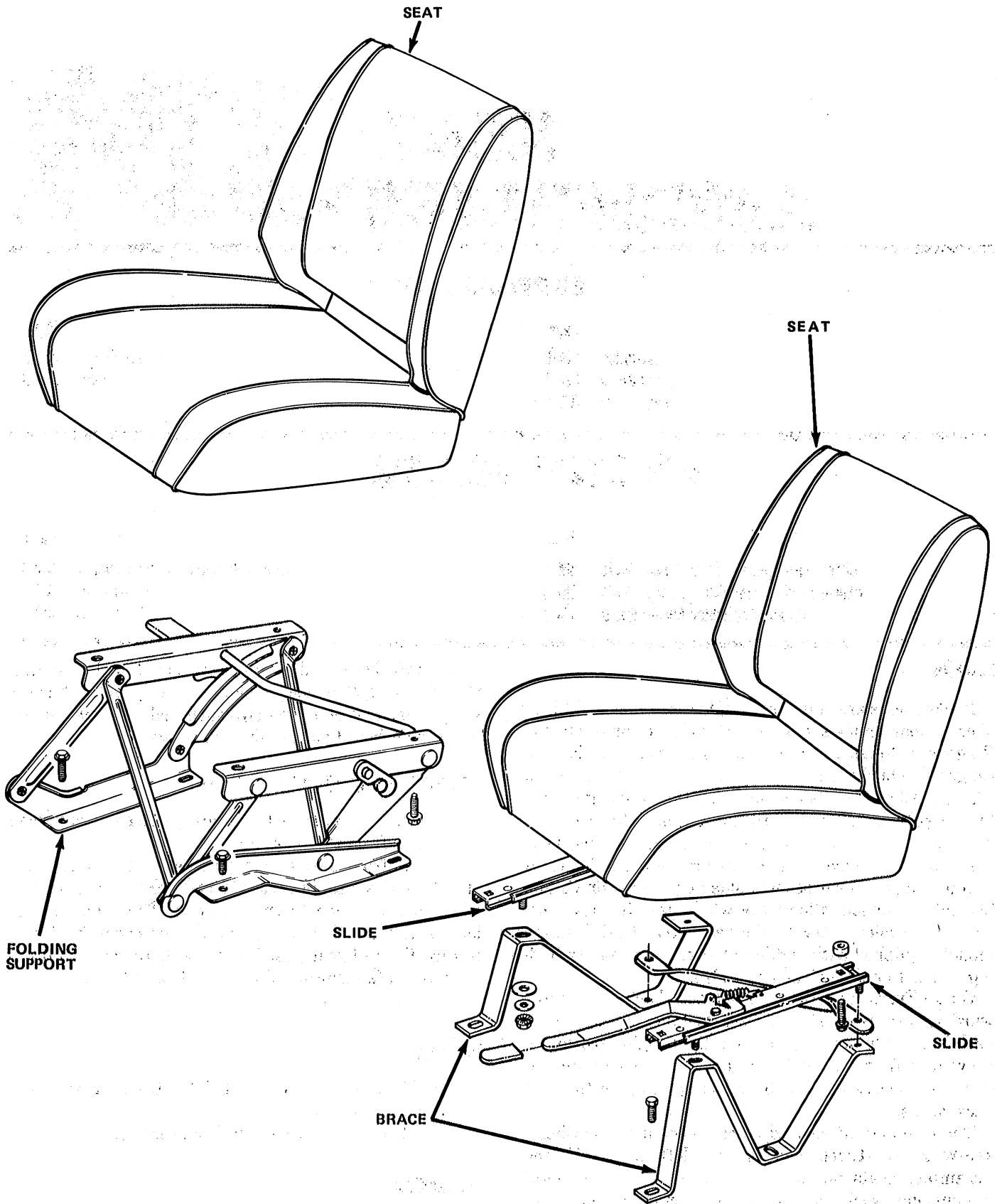

Fig. 3M-1 Bucket Seats—CJ and Scrambler Models

CHEROKEE-WAGONEER-TRUCK BUCKET SEATS

The seats are removed by unfastening the supports and/or braces from the floorpan.

The front seat frame attaches to the seat slides and the seat slides, in turn, attach to braces or supports which are fastened to the floorpan. The seat may be locked in the full forward position, or every half inch toward the full rear position, for a distance of approximately five inches.

Removal

- (1) Remove screws attaching supports to floorpan.
- (2) Remove seat assembly from vehicle.

Installation

- (1) Position seat assembly in vehicle.
- (2) Install screws attaching supports to floorpan. Tighten screws to 20 foot-pounds (27 N•m) torque.

Forward Tilting Seat Back Replacement—Cherokee and Truck Models

- (1) If equipped with center armrest, remove bucket seat from vehicle.
- (2) Remove screw attaching side wing panel-to-hockey stick using Torx Bit Tool J-25359-C.
- (3) Remove screws attaching hockey sticks to bottom frame using Torx Bit Tool J-25359-C.
- (4) Remove seat back.
- (5) Position seat back on bottom frame and install screws attaching hockey sticks to bottom frame using Torx Bit Tool J-25359-C.
- (6) Position side wing panel on outboard hockey stick and install attaching screw using Torx Bit Tool J-25359-C.
- (7) Install bucket seat in vehicle, if removed.

Tilt Lock Pawl Assembly

Removal

- (1) Remove forward tilting seat back.
- (2) Remove screw attaching release handle-to-latching rod using Torx Bit Tool J-25359-C and remove handle.
- (3) Remove screws attaching plastic bumpers using Torx Bit Tool J-25359-C and remove bumpers.
- (4) Unzip upholstery and pull back.
- (5) Remove spring retainers attaching latching rod (fig. 3M-2).
- (6) Remove rod, pawl, and spring from seat.

Installation

- (1) Position pawl and spring in seat and install latching rod.
- (2) Install spring retainers attaching latching rod to seat.

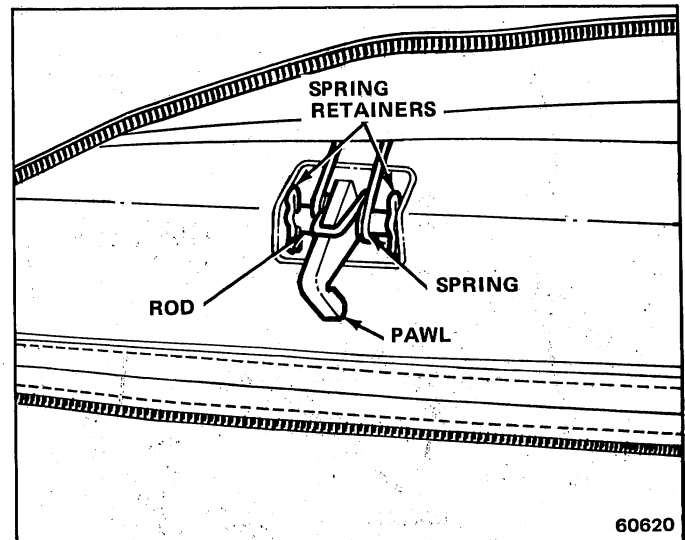

Fig. 3M-2 Tilt Lock Pawl Assembly

- (3) Pull upholstery over pad, zip up and tuck end of zipper under upholstery.
- (4) Position plastic bumpers on seat and install attaching screws using Torx Bit Tool J-25359-C.
- (5) Position release handle on latching rod and install attaching screw using Torx Bit Tool J-25359-C.
- (6) Install forward tilting seat back.

CHEROKEE-WAGONEER-TRUCK BENCH SEATS

The seats are removed by unfastening the supports and/or braces from the floorpan.

The front seat frame attaches to the seat slides and the seat slides, in turn, attach to supports which are fastened to the floorpan. The seat may be locked in the full forward position, or every half inch toward the full rear position, for a distance of approximately five inches.

On bench seats and bucket seats, a latch wire connects the right and left spring-loaded locking levers, facilitating the simultaneous unlocking or locking of both seat adjusting slides.

Removal

- (1) Remove screws attaching supports to floorpan.
- (2) Remove seat assembly from vehicle.

Installation

- (1) Position seat assembly in vehicle.
- (2) Install screws attaching supports to floorpan. Tighten screws to 20 foot-pounds (27 N•m) torque.

Adjustment

- (1) Locate turnbuckle under bench seat (fig. 3M-3). Loosen turnbuckle wingnut.

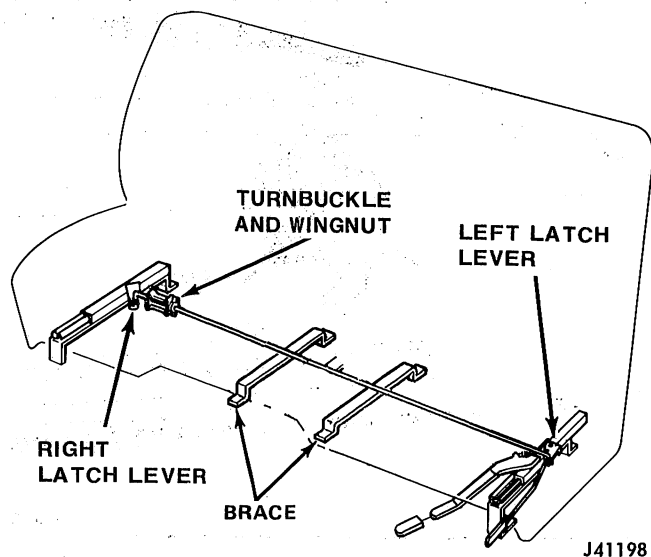

Fig. 3M-3 Front Seat Adjustment

- (2) Tighten turnbuckle until slack is removed from wire.
- (3) Back off turnbuckle three turns.
- (4) Secure wingnut up against turnbuckle.
- (5) Check for proper seat adjustment operation. If right side of seat will not release, increase tension by tightening turnbuckle. If right side of seat will not lock in place, decrease tension by loosening turnbuckle.

CJ AND SCRAMBLER FLOOR CONSOLE

The beverage container type floor console (fig. 3M-4), available only with bucket seat equipped models, is fabricated from molded plastic material. The floor console cover is provided with a lock and two depressions designed to hold beverage containers. The bottom of the floor console is equipped with a hole, in the rear, allowing ice water to drain onto the ground.

The oval head key is utilized to lock and unlock the cover.

Removal

- (1) Open console cover.
- (2) Remove screws attaching console to floorpan.
- (3) Remove console assembly from vehicle.

Installation

- (1) Position console assembly in vehicle.
- (2) Align drain hole with hole in floorpan and install attaching screws.
- (3) Close and latch console cover.

Console Cover Seal

The console cover seal is attached to the console. The foam seal may be replaced after opening the cover.

Console Cover Lock

Lock Cylinder Removal

- (1) Open console cover.
- (2) Remove screw attaching retainer to lock. Remove retainer from lock.
- (3) Remove lock, cylinder and key as unit from cover.
- (4) Manually set latch to simulate closed cover position, turn key and cylinder counterclockwise and lift out of lock.

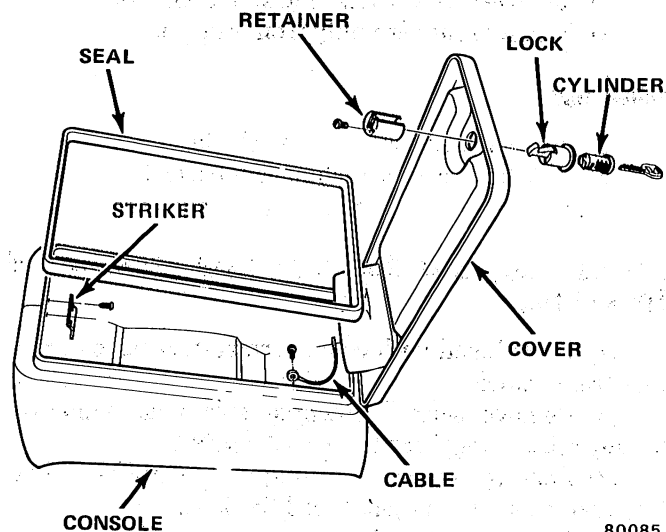

Fig. 3M-4 Floor Console Components

Lock Cylinder Installation

- (1) Manually set latch to simulate closed cover position.
- (2) Insert key and cylinder into lock and turn clockwise. Release latch and remove key.
- (3) Position assembled lock in cover and install retainer and attaching screw.

SEAT BELTS

Removal

- (1) Remove seat belt anchor bolt with Torx Bit Tool J-25359-C.
- (2) Remove seat belt.
- (3) Remove shoulder belt guide cover from guide, if equipped.
- (4) Remove guide bolt with Torx Bit Tool J-25359-C.
- (5) Obtain access to seat belt retractors by removing trim covers.
- (6) Remove seat belt retractors anchor bolts with Torx Bit Tool J-25359-C.
- (7) Remove seat belt retractor.
- (8) Inspect seat belt material for evidence of wear, cuts, or fraying. Replace as required.

Installation

(1) Install seat belt and seat belt retractor anchor bolts. Tighten to 25 to 35 foot-pounds (34 to 47 N•m) torque.

(2) Position shoulder belt guide on B-pillar or roll bar and install bolt with Torx Bit Tool J-25359-C.

(3) Install shoulder belt guide cover.

(4) Install seat belt retractor trim cover.

REAR SEATS

	Page
Cherokee-Wagoneer Seats	3M-5
CJ Seats	3M-5

	Page
Seat Belts	3M-6

CJ SEATS

The rear seat assembly (fig. 3M-5) is mounted by bolts to supports which, in turn, are secured to the floorpan of the vehicle by bolts.

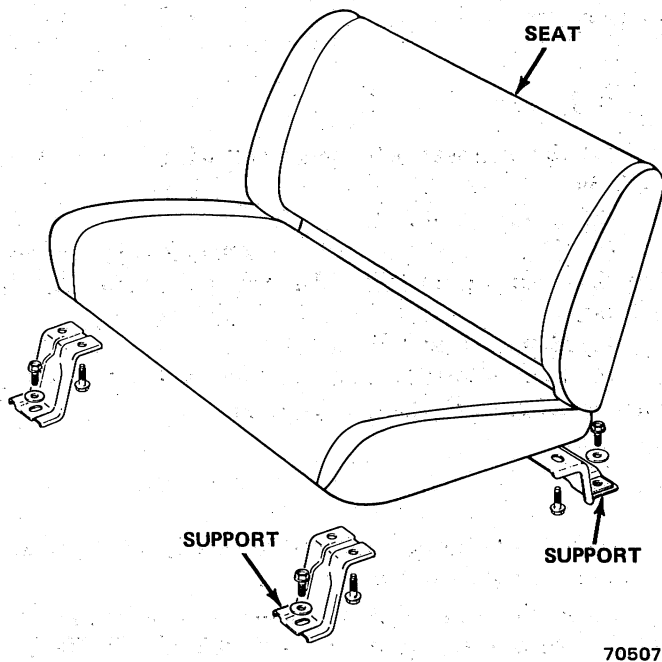

70507

Fig. 3M-5 Rear Seat Assembly—CJ Models

All seats are of spring design and utilize padding and foam rubber in their construction.

Removal

- (1) Remove bolts attaching rear seat assembly to floorpan.
- (2) Remove rear seat assembly from vehicle.

Installation

- (1) Position rear seat assembly in vehicle.
- (2) Install bolts attaching rear seat assembly to floorpan.

CHEROKEE-WAGONEER SEATS

The full width rear seat is attached to the floorpan by two hinges to allow the seat to be folded forward or removed to provide an enlarged rear cargo area (fig. 3M-6).



Fig. 3M-6 Rear Cargo Area with Rear Seat Removed

A latch on each side of the rear seat back engages a striker bolted into cage nuts on the rear wheelhouse panels. The cage nuts allow movement for striker adjustment.

To tilt the seat back forward, release the latches on the right and left side by raising the latch lever (fig. 3M-7) and simultaneously pulling the seat back forward.

A rear seat holding strap, attached to the right door pillar, prevents the seat from falling backward when the seat is in the folded position. An eye on the strap is engaged with the chrome plated stud to prevent the seat from falling backward. The strap should always be connected to the stud whenever the seat is in the folded position.

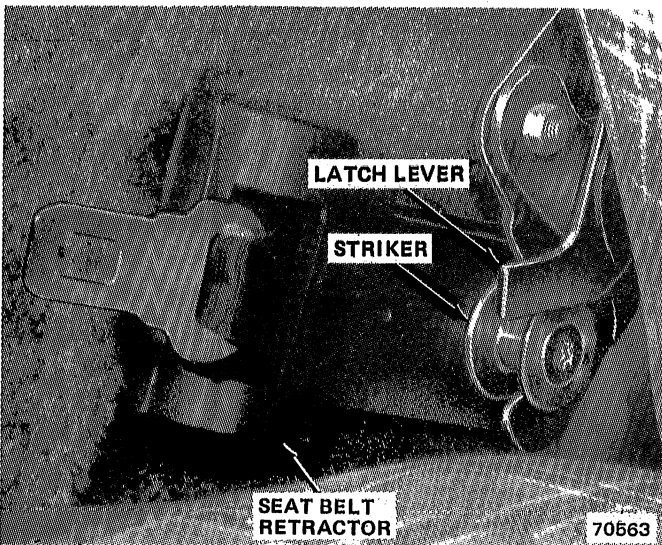

Fig. 3M-7 Rear Folding Seat—Latched Position

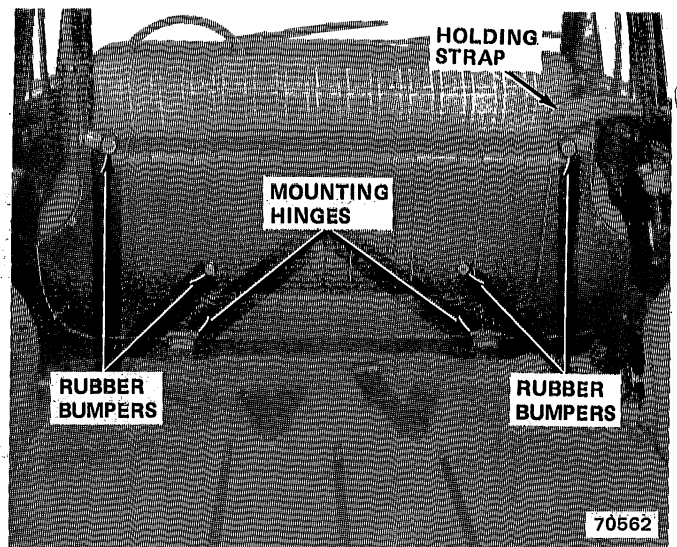

Fig. 3M-8 Rear Seat Assembly

Removal

- (1) Release latch at lower right side of seat back. Raise complete seat assembly forward (fig. 3M-8).
- (2) Lift complete seat assembly from two floor mounting hinges.
- (3) Remove seat assembly from vehicle.

Installation

- (1) Install seat assembly onto hinges.
- (2) Position seat back in proper location.
- (3) Secure seat back latch.

Adjustment

- (1) Tilt seat back forward and loosen striker bolt to allow forced movement of striker.
- (2) Raise seat back to upright position and tap striker into position for maximum latch/striker engagement.
- (3) Unlatch seat back carefully so as not to change striker position and tighten striker securely.
- (4) Check striker/latch operation.

SEAT BELTS

Removal

- (1) Remove seat belt anchor bolt with Torx Bit Tool J-25359-C.
- (2) Remove seat belt.
- (3) Obtain access to seat belt retractors by removing rear seat striker (fig. 3M-7) using Torx Bit Tool J-25359-C.
- (4) Remove seat belt retractor.
- (5) Inspect seat belt material for evidence of wear, cuts, or fraying. Replace as required.

Installation

- (1) Install seat belt anchor bolt. Tighten to 25 to 35 foot-pounds (34 to 47 N•m) torque.
- (2) Position seat belt retractor on wheelhouse and install rear seat striker using Torx Bit Tool J-25359-C.
- (3) Check striker/latch operation.

POWER SEATS

	Page		Page
Adjuster	3M-8	Motor	3M-8
Cable and Housing	3M-8	Seat Assembly	3M-8
General	3M-6	Servicing Procedures	3M-7
Horizontal and Vertical Transmissions	3M-8		

GENERAL

The power seats can be adjusted in six different directions up, down, forward, back, tilt forward, or tilt rearward.

The control switch is located on the lower outboard side of the seat. The front lever on the switch (fig. 3M-9) raises or lowers (tilts) the front of the seat, the center lever raises or lowers the complete seat by moving the

switch up or down. It also moves it forward or rearward by moving the switch forward or rearward. The rear lever raises or lowers (tilts) the back of the seat.

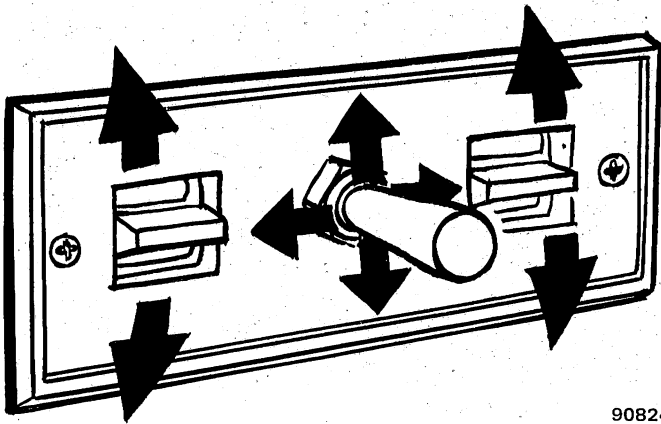

90824

Fig. 3M-9 Power Seat Controls

A three armature permanent magnet reversible motor is coupled through cables to the rack and pinion assemblies located in the seat tracks, providing the various seat movements.

The electrical circuit is protected by a 30 amp circuit breaker located on the fuse panel on the inside of the cowl panel to the left of the steering column.

SERVICING PROCEDURES

Test

Before any testing is attempted, the battery should be fully charged and all connections and terminals cleaned and tightened to insure proper continuity and grounds.

With the dome light on, apply the switch in the direction of failure. If the dome light dims, the seat may be jamming. Check for binding. If the dome light does not dim, then proceed with the following electrical tests.

(1) Disconnect wiring harness at connector under seat. Connect 12 volt test lamp between red and black wire in female connector on harness. If test lamp lights, harness to seat is good. If test lamp does not light, check as follows:

- (a) Current at fuse panel circuit breaker.
- (b) Continuity in red wire between fuse panel and harness connector under seat.
- (c) Continuity in black wire and proper connection to ground.

(2) Remove test lamp and connect harness.

(3) Remove switch from seat harness.

(4) To check rear motor, connect covered jumper wire between red terminal in center section (fig. 3M-10) and either light blue or orange connection in front section. Connect second covered jumper wire between black

terminal in center section and open connection in front section. If motor does not operate, reverse jumpers in front section. If motor still does not operate, either harness or complete three motor assembly may be defective.

(5) To check center motor, connect covered jumper wire between red terminal of center section and either white or tan connection in center section. Connect second covered jumper wire between black terminal in center section and open connection in center section. If motor does not operate, reverse white and tan jumpers. If motor still does not operate, either harness or complete three motor assembly should be replaced.

(6) To check front motor, connect covered jumper wire between red terminal in center section and either green or yellow connection in rear section. Connect second covered jumper wire between black terminal in center section and open connection in rear section. If motor does not operate, reverse jumpers in the section. If motor still does not operate, either harness or complete three motor assembly should be replaced.

(7) If all motors and seat operate properly this indicates that switch is bad and should be replaced.

For specific continuity checks, see Power Seat Wiring Diagram at back of this manual.

WIRE COLOR	FUNCTION
ORANGE	POWER SEAT - FRONT UP
LIGHT BLUE	POWER SEAT - FRONT DOWN
TAN	POWER SEAT - FORWARD
WHITE	POWER SEAT - REARWARD
LIGHT GREEN	POWER SEAT - REAR DOWN
YELLOW	POWER SEAT - REAR UP
BLACK	POWER SEAT - GROUND
RED W/O TR.	POWER SEAT - IGNITION FEED

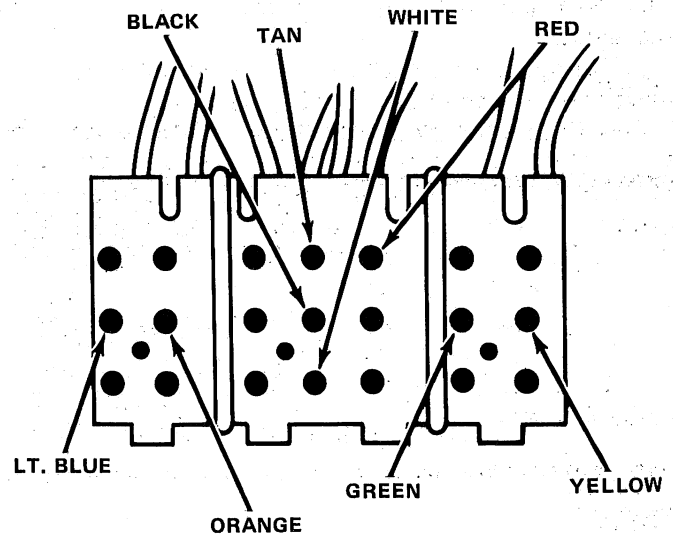

90825

Fig. 3M-10 Electrical Test Locations—Driver's Side

SEAT ASSEMBLY**Removal**

- (1) Disconnect battery negative cable.
- (2) Remove attaching nuts holding seat assembly to floorpan.
- (3) Tilt seat and disconnect wiring harness.
- (4) Remove seat assembly from vehicle.

Installation

- (1) Position seat assembly in vehicle.
- (2) Connect wiring harness.
- (3) Install and tighten attaching nuts.
- (4) Connect battery negative cable and check seat operation.

ADJUSTER**Removal**

- (1) Remove seat assembly from vehicle following procedure outlined above.
- (2) Lay seat on its back on clean surface.
- (3) Remove bolts attaching adjuster to seat assembly.

Installation

- (1) Lay seat on its back on clean surface.
- (2) Position adjuster to seat assembly and install attaching bolts.
- (3) Install seat assembly following procedure outlined above.

MOTOR**Removal**

Any time the motor, cable and housing assemblies or vertical and horizontal transmission assemblies require maintenance, the assemblies must be synchronized to insure easy and proper operation.

- (1) Remove seat assembly from vehicle following procedure outlined above.
- (2) Lay seat assembly on its back on clean surface.
- (3) Remove motor mounting screws (fig. 3M-11).
- (4) Carefully disconnect housings and cables from motor assembly.

Installation

- (1) Place motor assembly into position.
- (2) Carefully connect cables and housings to motor assembly.

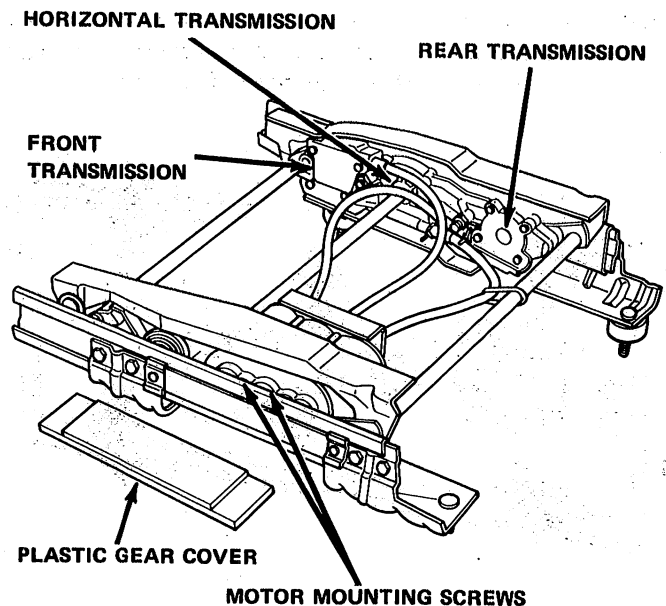

90826

Fig. 3M-11 Seat Track Assembly

- (3) Install mounting screws.
- (4) Install bolt holding motor assembly to adjuster.
- (5) Install seat assembly following procedure outlined above.

CABLE AND HOUSING**Removal**

Any time the motor, cable and housing assemblies or vertical and horizontal transmission assemblies require maintenance, the assemblies must be synchronized to insure easy and proper operation.

It is recommended that any time a cable is to be replaced that the motor assembly be removed also for ease of replacement.

- (1) After motor has been disconnected, remove corbin clamp from cable housing then slide cable and housing out of connector.

Installation

- (1) Insert cable and housing into connector and install corbin clamp.
- (2) Install motor assembly.

HORIZONTAL AND VERTICAL TRANSMISSIONS

Transmissions are not removable and no maintenance is required. If transmission fails, replace entire seat adjuster assembly.

CARPETING

	Page		Page
Floor Carpet	3M-9	Rear Compartment Carpet	3M-9
Front Floor Carpet	3M-9	Wheelhouse Carpet	3M-9

FLOOR CARPET

The rear floor carpet is held in position by the seats, center console, seat belts, sill plates and other components.

When removing and installing the rear floor carpet it may be necessary to remove and install the above items.

FRONT FLOOR CARPET

On Wagoneer, Cherokee, and Truck models the front floor carpet is held in position by the seats, seat belts, sill plates and other components. On CJ and Scrambler models the front floor carpet is held in position by velcro strips. The CJ-7 Limited model front floor carpet is glued into position.

When removing and installing the carpet, it will also be necessary to remove and install the above items also.

When replacing the front floor carpet, position the carpet in the vehicle and cut the openings in the carpet using a sharp knife or razor blade for such things as the floor shifter, if equipped.

REAR COMPARTMENT CARPET

The rear compartment carpet is fitted to the rear compartment and is held in position by the skid strip screws and rear seat. On CJ models the rear compartment carpet is held in position with glue and velcro strips.

The replacement carpet may require some modifications to accommodate these items.

WHEELHOUSE CARPET

The wheelhouse carpet is held in place by a combination of the trim panel and adhesive on the senior line vehicles.

When installing the wheelhouse carpet on the senior line vehicles apply 3M General Trim Adhesive, or equivalent to the backside of carpet before installing.

On CJ models the wheelhouse carpet is held in position by glue and velcro strips.

Tools

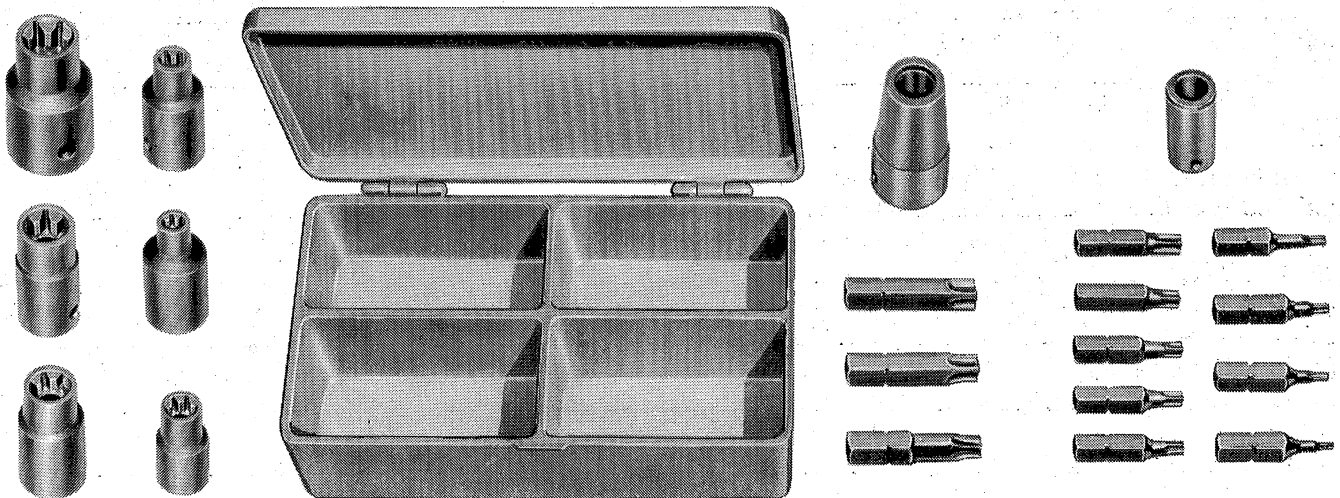

J-25359-C TORX BIT AND SOCKET SET

NOTES

[Faint, illegible handwritten notes on lined paper]