

# CLUTCH 2A

## SECTION INDEX

	Page		Page
Clutch Service—Four-Cylinder CJ-Scrambler	2A-9	General Information	2A-1
Clutch Service—Six- and Eight-Cylinder Models	2A-15	Tools	2A-22

## GENERAL INFORMATION

	Page		Page
Clutch Adjustments	2A-7	General	2A-1
Clutch Service	2A-2	Service Diagnosis	2A-2
Clutch Linkage	2A-8		

### GENERAL

#### Six- and Eight-Cylinder Models

The clutch assembly used in eight-cylinder Cherokee, Wagoneer and Truck models consists of a single dry-disc driven plate and a spring and lever-type clutch cover (fig. 2A-1). Two clutch cover styles are used. An 11.0-inch (27.9 cm) diameter semi-centrifugal cover is used on Cherokee, Wagoneer and Truck models with an eight-cylinder engine. An 10.5-inch (26.7 cm) diameter diaphragm-type clutch cover is used on six-cylinder CJ, Scrambler, Cherokee, Wagoneer and Truck models.

#### Four-Cylinder CJ and Scrambler Models

The clutch assembly used in four-cylinder CJ and Scrambler models consists of a diaphragm-type clutch cover and a single dry-disc driven plate. The cover consists of a one-piece diaphragm spring with integral release fingers (fig. 2A-2). The driven plate consists of a steel hub with four integral cushion springs and the friction material which is riveted to the hub (fig. 2A-3). The clutch cover and driven plate diameter is 9.250 inches (23.5 cm).

#### Clutch Hydraulic System—Four-Cylinder CJ and Scrambler Models

A hydraulic-clutch operating system is used on CJ and Scrambler models equipped with the 2.5 liter four-cylinder engine (fig. 2A-4). The system consists of a clutch

cylinder, a slave cylinder, and an interconnecting hydraulic line. The clutch cylinder is mounted on the dash panel next to the brake master cylinder. The slave cylinder is mounted on the clutch housing. The clutch cylinder is connected directly to the clutch pedal. The slave cylinder is connected to the throwout lever.

#### Clutch Hydraulic System Operation

When the clutch pedal is pressed down, hydraulic fluid from the clutch cylinder flows into the slave cylinder causing the slave cylinder push rod to extend. Since the push rod is connected to the throwout lever, the lever moves the throwout bearing into contact with the clutch cover release fingers to disengage the clutch.

**NOTE:** On four-cylinder CJ and Scrambler models with the clutch hydraulic operating system, the clutch pedal must be fully depressed before complete clutch disengagement will occur.

#### Clutch Hydraulic Fluid

The hydraulic fluid that operates the clutch hydraulic mechanism is contained in the clutch cylinder reservoir. When adding fluid to, or refilling the system after service operations, use AMC/Jeep brake fluid, or equivalent, marked SAE J-1703 or DOT 3 only. Do not use any type of mineral or paraffin base oils in the system. These fluids will damage the rubber parts in the clutch and slave cylinders.

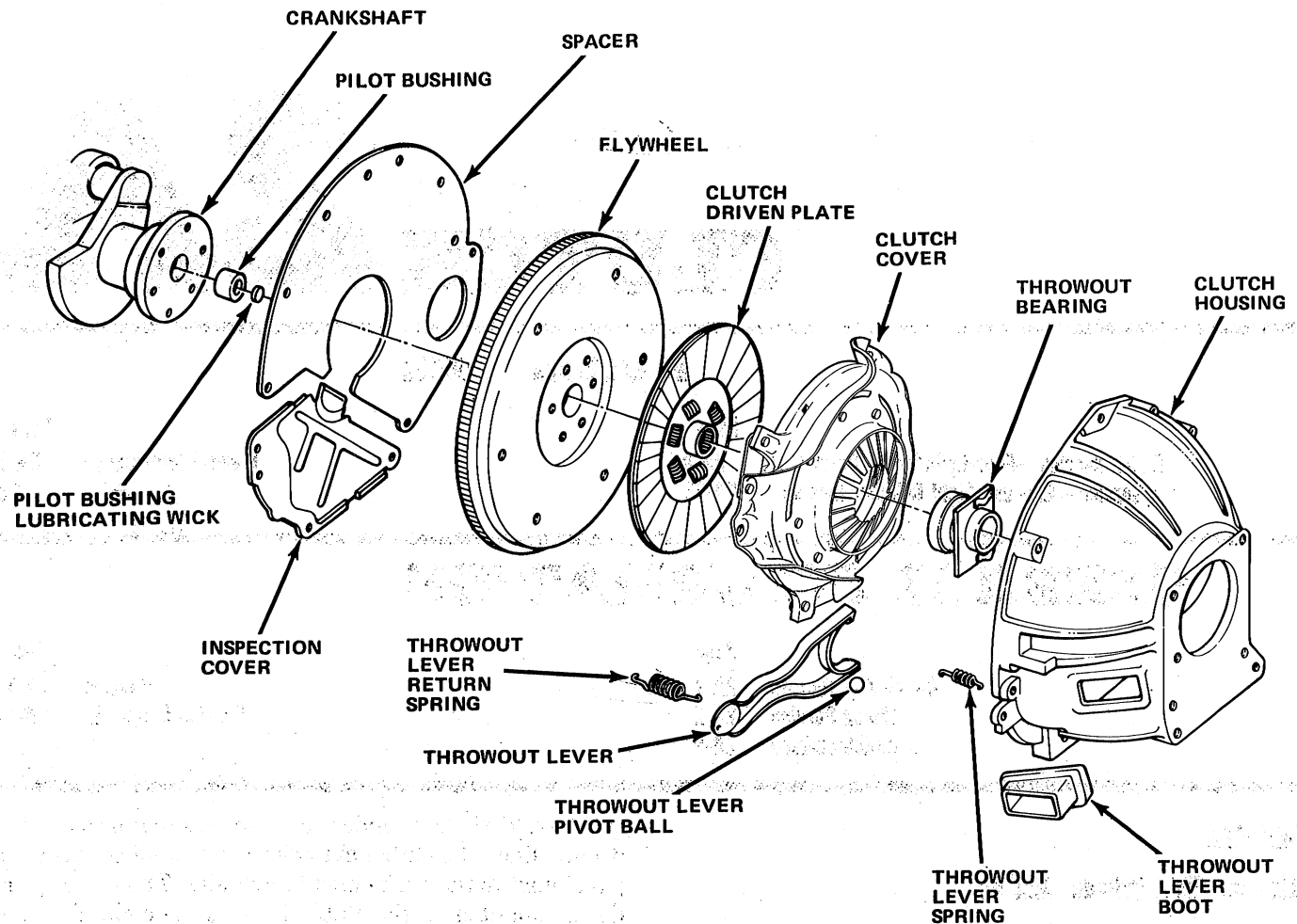

90031

Fig. 2A-1 Clutch Assembly—Six- and Eight-Cylinder Models

### Clutch Hydraulic Fluid Level

The desired fluid level is indicated on the side of the clutch cylinder. When refilling the system, fill the cylinder reservoir to the level indicated on the side of the reservoir only. Do not overfill the reservoir.

### Throwout Bearing

CJ and Scrambler models equipped with the 2.5 liter four-cylinder engine use a throwout bearing that is similar to the bearing used on six-cylinder CJ and Scrambler, and six- and eight-cylinder Cherokee, Wagoneer and Truck models. The four-cylinder throwout bearing contact face is slightly crowned. The six- and eight-cylinder throwout bearing contact face is flat.

### CLUTCH SERVICE

On four-cylinder CJ and Scrambler models, the components that form the clutch hydraulic system are fully

serviceable. Refer to the Clutch Service—Four-Cylinder CJ and Scrambler Models section for all necessary service procedures.

On all models the clutch cover, driven plate and throwout bearing are serviced as assemblies only. Do not attempt to disassemble any of these components to effect repairs. If any of these components are damaged or severely worn, replace the component as an assembly only.

### SERVICE DIAGNOSIS

#### General

Clutch problems can generally be assigned to one of the following categories defined as:

- Clutch chatter
- Clutch slippage or inadequate clutch pedal free play
- Clutch drag or inadequate clutch release
- Clutch pedal pulsation
- Clutch-related vibration
- Clutch area noises

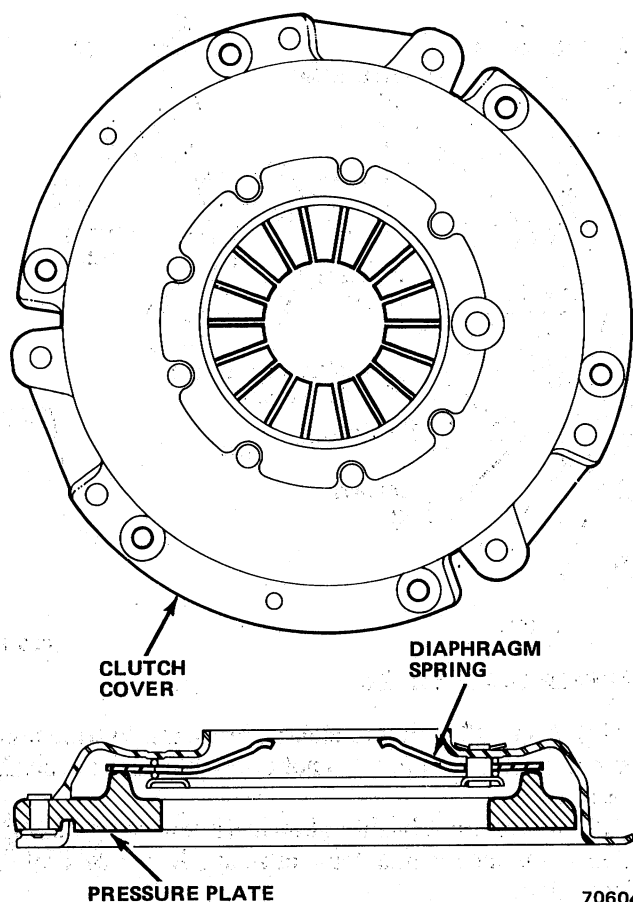

Fig. 2A-2 Clutch Cover—Four-Cylinder CJ and Scrambler Models

Each category is described in common complaint language and followed by simplified diagnosis and repair procedures.

**NOTE:** Before performing any of the following diagnosis and repair procedures, adjust pedal free play on vehicles with six- and eight-cylinder engines and be sure the clutch pedal returns to the pedal stop completely. On four-cylinder CJ and Scrambler models, check the hydraulic cylinders and connecting line for damage and leakage.

### Clutch Chatter

Clutch chatter can be described as a shaking or shuddering sensation felt throughout the vehicle. Chatter usually develops when the clutch cover pressure plate makes initial contact with the driven plate and ceases when the clutch is fully engaged (clutch pedal released). Check clutch operation as follows:

**WARNING:** The following test requires clutch engagement to the point of vehicle movement. Do not allow anyone to stand at the front or rear of the vehicle during this test.

(1) Start engine, press clutch pedal to floor and shift transmission into first gear.

(2) Increase engine speed to 1200/1500 rpm and slowly release clutch pedal. When pressure plate makes initial contact with driven plate, note clutch operation. Press clutch pedal to floor and release accelerator pedal.

(3) Shift transmission into reverse and repeat procedure outlined in step (2).

(4) If clutch chatter does not develop in either gear range, increase engine speed to 1700/2200 rpm and repeat steps (2) and (3).

(5) If clutch chatter does not develop after performing tests outlined in steps (1) through (4), problem may be improper operation by owner. If clutch chatter does develop, proceed to next step.

(6) Raise vehicle on hoist.

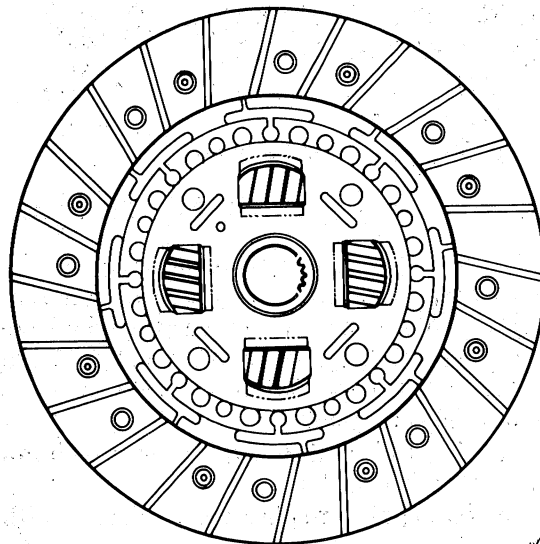

Fig. 2A-3 Clutch Driven Plate—Four-Cylinder CJ and Scrambler Models

(7) Check for loose or broken front or rear engine support cushions. Tighten or replace as necessary. Check for loose clutch housing-to-engine or housing adapter-to-transmission attaching bolts. Tighten as necessary. Refer to torque specifications in this section. Check for binding, worn, bent or broken clutch linkage components. Lubricate or replace as necessary.

(8) If components inspected are in good condition, proceed to next step. If one or more problems were discovered and corrected, lower vehicle and repeat step (1). If chatter is still evident, proceed to next step.

(9) Remove transmission and clutch components as outlined in this chapter.

**NOTE:** Whenever the clutch components are removed, also remove the pilot bushing lubricating wick, soak the wick in engine oil and reinstall the wick before assembly.

(10) Check for oil or grease contamination of driven plate. If contaminated, correct cause of contamination and replace driven plate.

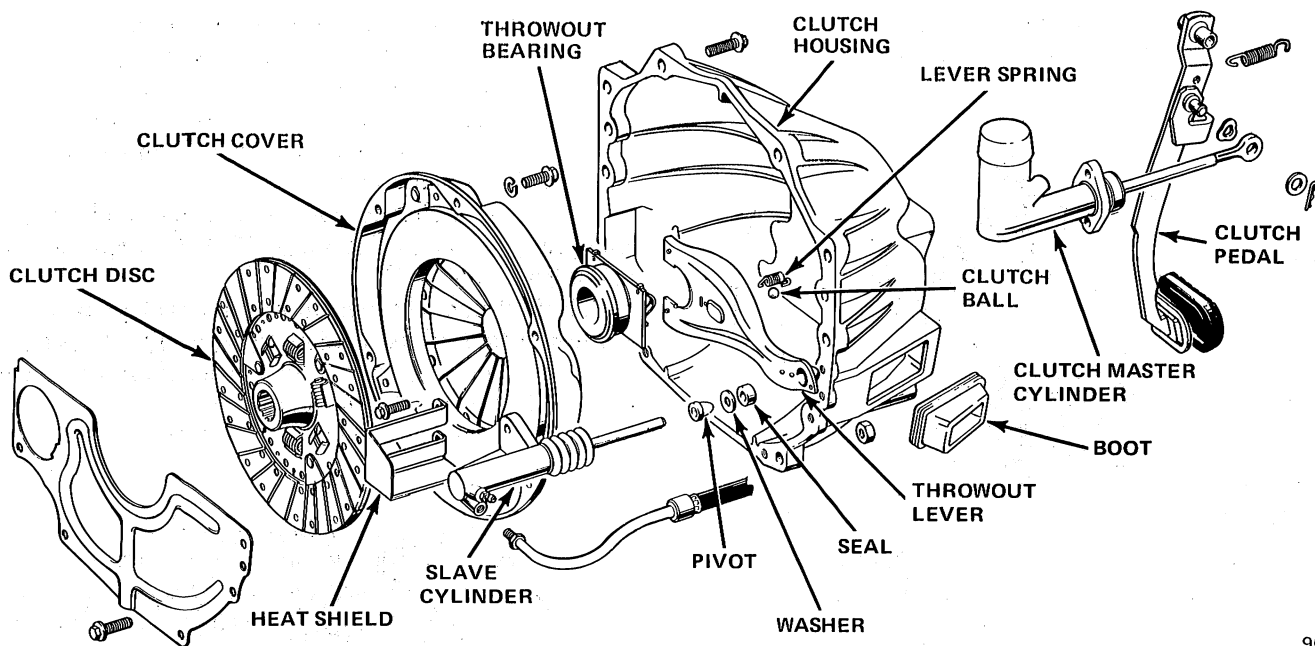

Fig. 2A-4 Clutch Assembly—Four-Cylinder CJ and Scrambler Models

90801B

(11) Check clutch cover for broken or collapsed apply springs and inspect surface of pressure plate for deep scoring, cracks, heat checking, or warping (check surface with straightedge). Replace clutch cover if it exhibits any of these conditions. Do not replace clutch cover if cover is in good condition.

(a) Clean oil and dirt from cover with mineral spirits and allow to air dry.

(b) Sand pressure plate surface lightly with fine emery cloth.

(c) Lubricate release lever pivots and check release lever height. Adjust height if necessary.

**CAUTION:** Apply lubricant to pivots sparingly. Excessive lubrication could result in grease contamination of the pressure plate and driven plate surfaces.

(12) Inspect crankshaft pilot bushing. Replace bushing if worn, deeply scored, or discolored.

**NOTE:** Soak replacement bushing in engine oil before installation.

(13) Inspect condition of splines on transmission clutch shaft and in driven plate hub. If splines are worn, galled, chipped or broken, replace clutch shaft or driven plate. Remove corrosion, rust, or burrs from splines using oilstone or fine-tooth file. Install driven plate on clutch shaft. Plate must move freely on shaft.

(14) If all clutch components are in good condition, proceed to next step. If one or more components were determined to be faulty, repair as necessary and proceed to next step.

(15) Check clutch housing alignment as outlined in this chapter. Correct alignment if necessary and proceed to next step.

(16) Apply thin film of chassis lubricant to transmission clutch shaft splines. Do not apply lubricant to shaft pilot hub.

(17) Install pilot bushing lubricating wick and install clutch components and transmission. Refer to Clutch Installation.

**NOTE:** Do not replace the throwout bearing unless it is defective or damaged. Refer to Clutch Area Noises.

### Clutch Slippage Or Inadequate Clutch Linkage Free Play

Clutch slippage can be described as a condition in which the engine overspeeds but does not generate any increase in torque supplied to the wheels. Clutch slippage occurs when the driven plate is not gripped firmly between the flywheel and clutch cover pressure plate and rotates or slips between them at high torque. Clutch slippage can occur during initial acceleration or during subsequent shifts. Check clutch operation as follows:

(1) Block wheels and apply parking brake.

(2) Operate engine until it reaches normal operating temperature.

(3) Shift transmission into third gear and increase engine speed to 2000 rpm.

**WARNING:** Do not permit anyone to stand in front of the vehicle during this test.

(4) Slowly release clutch pedal until clutch is fully engaged.

**CAUTION:** Do not allow the clutch to be engaged for more than 5 seconds at a time as the clutch components could be damaged.

(5) If engine stalls within 5 seconds, clutch is not defective. If engine continues to run, proceed to next step.

(6) Raise vehicle on hoist. Check clutch linkage for binding, worn, broken, or bent components. Lubricate or replace as necessary. If all components inspected are in good operating condition, proceed to next step.

(7) If one or more problems were discovered and corrected during inspection in previous step, repeat steps (1) through (4). If clutch slippage is corrected, stop repair. If slippage persists, proceed to next step.

(8) Remove transmission and clutch components. Refer to Clutch Removal.

**NOTE:** *Whenever the transmission is removed, also remove the pilot bushing lubricating wick, soak the wick in engine oil, and reinstall the wick before assembly.*

(9) Inspect driven plate. If 1/16 inch (2 mm) or less friction material remains above rivet heads, or plate is severely glazed or contaminated with oil or grease, replace driven plate.

**NOTE:** *If the driven plate is contaminated, determine the cause and make correction before proceeding.*

(10) Inspect clutch cover. If cover is heat-checked, has broken or collapsed springs, or exhibits signs of overheating (e.g., has blue coloration), replace cover. If cover does not exhibit any of these conditions, do not replace it.

(a) Clean oil and dirt from cover using mineral spirits and allow cover to air dry.

(b) Sand pressure plate surface lightly using fine emery cloth.

(c) Lubricate cover release lever pivots and check and adjust release lever height as necessary.

**CAUTION:** *Apply lubricant to the pivots sparingly. Excessive lubrication could result in grease contamination of the driven plate and pressure plate surfaces.*

(11) Check throwout bearing mounting surface of transmission front bearing cap for galling, deep scores, or roughness. Install throwout bearing on bearing cap and check for smooth fore/aft movement. Replace bearing or bearing cap as necessary if bind occurs. Fill throwout bearing groove with chassis grease and apply thin coat of grease to bearing mounting surface of front bearing cap.

**CAUTION:** *The throwout bearing has retaining springs which position the bearing on the throwout lever. Check these springs for distortion, loss of tension, or for being bent or broken. Replace the bearing if these springs are damaged.*

**NOTE:** *Do not replace the throwout bearing unless it is actually defective or damaged. Refer to Clutch Area Noises.*

(12) Apply thin film of chassis grease to transmission clutch shaft splines. Do not apply grease to shaft pilot hub.

(13) Install pilot bushing and lubricating wick.

(14) Install clutch components and transmission. Refer to Clutch Installation.

(15) Lower vehicle.

### Clutch Drag Or Inadequate Release

Clutch drag can be described as a condition in which the clutch driven plate, and consequently the transmission clutch shaft, does not come to a complete stop after the clutch pedal is depressed (clutch disengaged). Clutch drag can cause gear clash when shifting into reverse or hard or difficult shifting. Check clutch operation as follows.

**NOTE:** *Occasionally, the clutch driven plate and clutch shaft will require approximately 5 seconds to lose momentum and come to a complete stop after initial clutch disengagement. This is normal and should not be mistaken for clutch drag.*

(1) Start engine, depress clutch pedal fully, and shift transmission into first gear.

(2) Shift transmission into neutral but **do not** release clutch pedal.

(3) Wait 5 to 10 seconds and shift transmission into reverse. If shift is smooth with no gear clash, clutch operation is normal. If shifting into reverse produces gear clash, proceed to next step.

(4) Raise vehicle on hoist. Check clutch linkage for binding, worn, broken or bent components. Lubricate or replace as necessary. If components are in good operating condition, proceed to next step. If one or more problems were discovered and repaired, lower vehicle and repeat steps (1) through (3). If clutch now operates correctly, stop repair. If clutch drag persists, proceed to next step.

(5) Remove transmission and clutch components. Refer to Clutch Removal.

**NOTE:** *Whenever the transmission is removed, also remove the pilot bushing lubricating wick, soak the wick in engine oil, and reinstall the wick before assembly.*

(6) Observe wear pattern on driven plate. If wear pattern is uneven (e.g., two areas heavily worn on one side, two only partially worn on opposite side), or has opposing wear patterns on front and reverse side, the driven plate is warped and should be replaced.

(7) Inspect clutch cover assembly. If clutch cover assembly has worn, bent, or broken release levers or lever pivots, is heavily scored, or warped, replace clutch cover assembly. If cover assembly does not exhibit any of these conditions, do not replace it.

(a) Clean oil and dirt from clutch cover with solvent and allow cover to air dry.

(b) Sand pressure plate surface lightly using fine emery cloth.

(c) Lubricate cover release lever pivots with chassis grease.

**NOTE:** *Apply lubricant to pivots sparingly. Excessive lubricant could result in grease contamination of pressure plate and driven plate surfaces.*

(8) Check and adjust clutch cover release lever height as necessary.

**NOTE:** *If the release lever height cannot be adjusted, the release lever(s) are bent. Replace the clutch cover.*

(9) Inspect crankshaft pilot bushing for heavy scoring, angular wear pattern, or discoloration. Replace as necessary. Be sure to soak bushing in engine oil before installation.

**NOTE:** *If the pilot bushing displays an angular-type wear pattern, check and correct clutch housing alignment before proceeding. Refer to Clutch Housing Alignment.*

(10) Inspect condition of splines on transmission clutch shaft and in driven plate hub. If severely worn, galled, or corroded, replace clutch shaft or driven plate. Corrosion, rust, or burrs can be removed from splines using an oilstone or fine-tooth file. Install driven plate on clutch shaft. Driven plate must move freely on shaft.

(11) If components inspected in previous steps are in good condition, proceed to next step. If one or more problems were discovered during inspection procedure, repair as necessary and proceed to next step.

(12) Check clutch housing alignment. Refer to Clutch Housing Alignment. Correct alignment if necessary and proceed to next step.

(13) Apply thin film of chassis grease to transmission clutch shaft splines. Do not apply grease to shaft pilot hub.

(14) Install pilot bushing lubricating wick.

(15) Install transmission and clutch components. Refer to Clutch Installation.

(16) Lower vehicle.

**NOTE:** *Do not replace the throwout bearing unless actually defective. Refer to Clutch Area Noises.*

### Clutch Pedal Pulsation

Clutch pedal pulsation can be described as a rapid up-and-down or pumping-type movement of the pedal that is not accompanied by any noise. In most cases, pedal movement is slight and cannot be observed but can be felt by the driver. However, on occasion, pedal movement will be great enough to be visually observed and cause a noticeable vibration.

Clutch pedal pulsation occurs when the throwout bearing makes initial contact with the clutch cover release levers (clutch partially disengaged), or at any time

the bearing is in contact with the release levers. Pulsation is usually caused by incorrect clutch release lever height or clutch housing misalignment. Check clutch operation as follows.

(1) Start engine, slowly depress clutch pedal until throwout bearing makes initial contact with clutch release levers, and check for pulsation.

**NOTE:** *Some minor pulsation is normal.*

(2) Continue to depress clutch pedal while checking for pulsation until pedal is fully depressed.

(3) If pulsation is not evident or is minor, stop repair. If pulsation is very rapid and can be felt throughout vehicle, refer to Clutch-Related Vibrations. If vehicle displays pulsation symptoms, proceed to next step.

(4) Remove transmission and clutch components. Refer to Clutch Removal.

(5) Remove pilot bushing lubricating wick and soak wick in engine oil.

(6) Inspect clutch cover release levers. If levers are bent or excessively worn, replace clutch cover and proceed to step (8). If release levers are in good condition, clean oil and dirt from clutch cover assembly using mineral spirits, allow assembly to air dry and proceed to next step.

(7) Sand clutch cover pressure plate surface lightly using fine emery cloth.

(8) Lubricate clutch cover release lever pivots lightly with chassis grease.

**NOTE:** *Apply lubricant to the pivots sparingly. Excessive lubrication could result in grease contamination of the driven plate and pressure plate surface.*

(9) Check and adjust clutch cover release lever height if necessary.

**NOTE:** *If release lever height cannot be adjusted, the levers are bent and the cover must be replaced.*

(10) Check clutch housing alignment. Refer to Clutch Housing Alignment. Correct alignment if necessary and proceed to next step.

(11) Apply thin film of chassis grease to transmission clutch shaft splines but do not apply grease to shaft pilot hub.

(12) Install pilot bushing lubricating wick.

(13) Install clutch components and transmission. Refer to Clutch Installation.

### Clutch Related Vibrations

Clutch related vibrations differ from pedal pulsations in frequency and magnitude. They usually occur at relatively high engine speeds (over 1500 rpm), are not affected by clutch pedal position, and can be felt throughout the vehicle.

Although clutch related vibrations are usually caused by clutch component imbalance, this condition occurs

very infrequently because the clutch cover and driven plate are balanced as a unit during assembly. At this time, the cover and plate are installed on the crankshaft/flywheel assembly and given a final fine-tune balance before installation in the vehicle.

Replacement of clutch components to correct vibrations should be performed only after exhausting all other possibilities. Check clutch operation as follows.

(1) Raise vehicle on hoist and check engine front support cushion interlocks for grounding. Repair as necessary. Check other engine components (e.g., exhaust manifold, valve cover, etc.) for grounding on body or frame. If one of these components is grounded, repair and check for vibration. If vibration ceases, stop repair. If vibration continues, lower vehicle and proceed to next step.

(2) Disconnect accessory drive belts one at a time, start engine, and check for vibration. If vibration stops after removal of a drive belt, cause of vibration is related to accessory driven by belt or by belt itself. Repair as necessary. If vibration persists after checking all belts and accessories, proceed to next step.

(3) Raise vehicle on hoist and remove transmission and clutch housing. Refer to Clutch Removal.

(4) Support engine firmly.

(5) Check for loose flywheel mounting bolts. Tighten bolts to 105 foot-pounds (142 N•m) torque if necessary and operate engine. If vibration ceases, stop repair. If vibration is still evident, proceed to next step.

(6) Check flywheel face runout while holding crankshaft end play to zero. If runout is 0.005 inch (0.12 mm) or less, proceed to next step. If runout exceeds 0.005 inch (0.12 mm), replace flywheel and operate engine. If vibration ceases, stop repair. If vibration is still evident, proceed to next step.

(7) Check for damaged crankshaft vibration dampener. If dampener is in good condition, proceed to next step. If dampener is damaged, replace dampener and operate engine. If vibration ceases, stop repair. If vibration is still evident, proceed to next step.

(8) Check clutch cover imbalance as follows:

(a) Remove clutch cover and driven plate from flywheel.

(b) Start and operate engine at speed where vibration occurred.

(c) If vibration ceases, replace clutch cover and recheck operation. If now OK, install clutch housing and transmission. Refer to Clutch Installation.

(9) Lower vehicle.

## Clutch Noises

### Throwout Bearing Noise

Throwout bearing noises can be described as whirring, grating, or grinding noises that occur when the clutch pedal is depressed (clutch disengaged).

These noises usually continue until the clutch pedal is fully released (clutch engaged) and the bearing is no longer in contact with the clutch cover release levers.

Throwout bearing noise is corrected by replacing the bearing as outlined in this chapter.

**NOTE:** *The throwout bearing should not be replaced as a matter of course when servicing the clutch cover or driven plate. Replace the bearing only if defective.*

### Transmission Clutch Shaft or Countershaft Bearing Noise

Transmission clutch shaft or countershaft bearing noises can be described as whirring, grating, or grinding noises which cease when the clutch pedal is depressed (clutch disengaged) or when the transmission is shifted into gear. These noises are most noticeable when the clutch pedal is fully released and the transmission is in neutral. Correction of these noises will require transmission removal and replacement of the problem bearing(s).

### Crankshaft Pilot Bushing Noise

Pilot bushing noises can be described as squealing, howling, or elephant-type trumpeting noises which are most noticeable when the engine is cold. These noises occur during the first few inches of clutch pedal travel as the pedal is being released (partial clutch engagement) with the transmission in gear. It can also occur in very cold weather when the pedal is fully depressed (clutch disengaged) and the engine is started with the transmission in neutral. To correct pilot bushing noise, replace bushing as outlined in this section.

## CLUTCH ADJUSTMENTS

### Four-Cylinder CJ and Scrambler Models

The clutch hydraulic mechanism is self-adjusting. Free play adjustments are not required nor is there any provision for such an adjustment.

### Six- and Eight-Cylinder Models

There are two clutch adjustments required: clutch pedal free play and clutch cover release lever height.

Clutch pedal freeplay should be checked and adjusted at the intervals specified in the Mechanical Maintenance Schedule, Chapter B, or whenever diagnosis indicates adjustment is needed. Refer to Clutch Pedal Free Play Adjustment in this section.

Clutch cover release lever height should be checked and adjusted whenever the cover is removed or replaced during service operations, or whenever diagnosis indicates adjustment is needed. Refer to the Clutch Service—Six- and Eight-Cylinder Models section in this chapter.

### Clutch Pedal Free Play Adjustment

- (1) Lift clutch pedal upward and against pedal stop (fig. 2A-1).
- (2) Raise vehicle.
- (3) On Cherokee, Wagoneer and Truck models, adjust clutch push rod lower ball pivot assembly in-or-out on push rod (fig. 2A-5) until bellcrank inner lever is parallel to front face of clutch housing. Lever should be slightly forward from vertical.
- (4) On all models, loosen release rod adjuster jamnut.
- (5) Turn release rod adjuster in or out to obtain specified clutch pedal free play.
- (6) Tighten release rod jamnut.
- (7) Lower vehicle.

### CLUTCH LINKAGE

The suspended-type clutch pedal is connected to the throwout lever through the clutch push rod, bellcrank outer and inner levers, and release rod (figs. 2A-5 and 2A-6). The throwout bearing is mounted on the transmission front bearing cap and acts directly against the clutch cover release levers to engage and disengage the

clutch. The bearing is actuated by a throwout lever mounted in the clutch housing. The lever pivots on a steel ball mounted inside the clutch housing.

The bellcrank pivots on ball studs mounted in the inner and outer support brackets (figs. 2A-5 and 2A-6). Idler bushings, installed in each end of the bellcrank provide bearing surfaces for the ball studs.

### Clutch Linkage Lubrication

The clutch linkage ball studs are the only linkage components that require periodic lubrication. The studs should be lubricated at the intervals specified in the Mechanical Maintenance Schedule, Chapter B.

### Lubrication Procedure

The bellcrank has a lubrication fitting to facilitate ball stud lubrication. Whenever lubrication is necessary, proceed as follows:

- (1) Raise vehicle.
- (2) Fill lube gun with lithium-base chassis grease.
- (3) Connect lube gun nozzle to bellcrank fitting and lubricate ball studs.
- (4) Remove lube gun and lower vehicle.

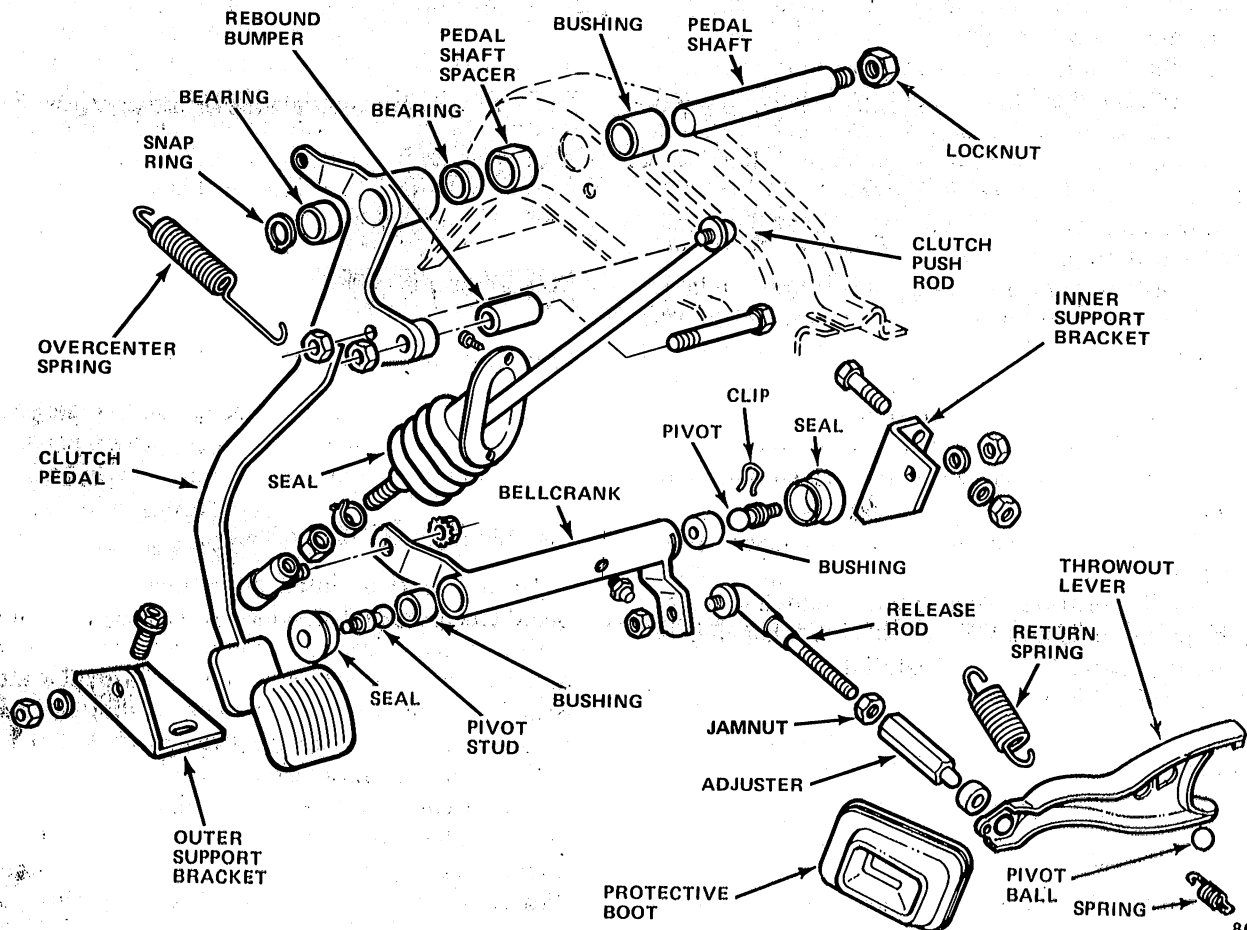
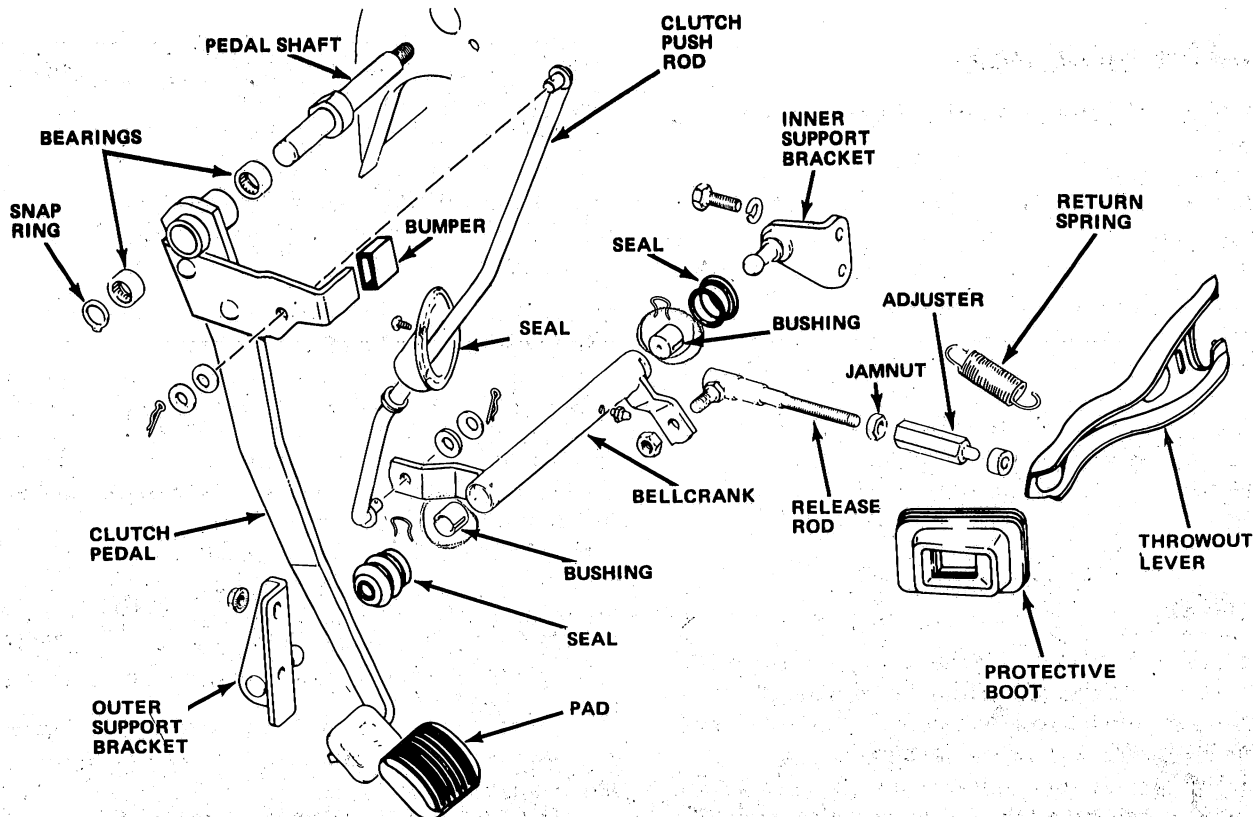

Fig. 2A-5 Clutch Linkage—Cherokee and Truck Models





60566

Fig. 2A-6 Clutch Linkage—Six-Cylinder CJ and Scrambler Models

## CLUTCH SERVICE— FOUR-CYLINDER CJ-SCRAMBLER MODELS

	Page
Clutch Cylinder Service	2A-12
Clutch Housing Alignment	2A-12
Clutch Hydraulic System Bleeding	2A-14
Clutch Installation	2A-10
Clutch Removal	2A-9
Flywheel Replacement	2A-11

	Page
Pilot Bushing Replacement	2A-11
Slave Cylinder Service	2A-13
Specifications	2A-15
Throwout Bearing and Lever	2A-11
Transmission Clutch Shaft	2A-12

### CLUTCH REMOVAL

(1) Remove screws attaching transmission shift lever boot to floorpan and slide boot upward on lever.

(2) Remove bolts attaching transmission shift lever housing to transmission (fig. 2A-7). Lift shift lever and housing upward and secure assembly to floorpan with wire.

(3) Raise vehicle.

(4) Mark rear propeller shaft and transfer case yoke for assembly alignment reference.

(5) Disconnect rear propeller shaft at transfer case. Move shaft aside and secure to underbody.

(6) Position safety stand under engine to support engine.

(7) Remove bolts/nuts attaching rear crossmember to frame rails and rear support cushion and remove crossmember.

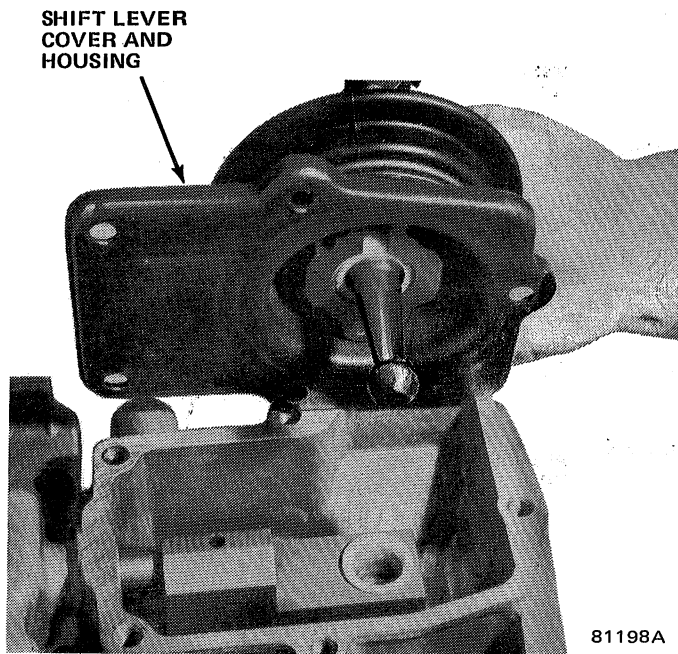

81198A

Fig. 2A-7 Shift Lever Removal—Models T-4, T-5

(8) Remove bolts attaching slave cylinder to clutch housing. Disengage cylinder push rod from throwout lever and move cylinder aside. Secure cylinder to underbody with wire, if necessary.

(9) Drain transfer case and disconnect speedometer cable.

(10) Disconnect backup lamp switch wire.

(11) Disconnect parking brake cable, if necessary.

(12) Disconnect transfer case vent hose at transfer case and disconnect 4WD indicator switch wire.

(13) Remove starter motor.

(14) Mark front propeller shaft and transfer case yoke for assembly alignment reference.

(15) Disconnect front propeller shaft from transfer case yoke. Move shaft aside and secure to underbody with wire.

(16) Remove transfer case shift lever as follows: Remove shifter shaft retaining nut. Remove cotter pins that retain shift control link pins in shift rods and remove pins. Remove shifter shaft and disengage shift lever from shift control links. Slide lever upward in boot to move lever out of way.

**NOTE:** On some models, the shifter shaft is threaded into the shift lever and must be unthreaded to remove it. On other models, the shaft is removed simply by sliding it out of the lever.

(17) Support transmission-transfer case assembly with transmission jack. Use safety chain to secure assembly on jack.

(18) Remove bolts attaching transmission to clutch housing and remove transmission-transfer case assembly.

(19) Remove throwout bearing from throwout lever.

(20) Remove bolts attaching clutch housing to engine and remove clutch housing.

(21) Mark position of clutch cover on flywheel for assembly alignment reference.

(22) Loosen clutch cover attaching bolts one or two turns at a time and in rotation to relieve spring tension on cover.

**CAUTION:** The clutch cover bolts must be loosened evenly and in rotation to avoid distorting the cover. The cover is a steel stamping and could be warped if removed improperly. If warped, the cover will cause clutch chatter after assembly.

(23) Remove clutch cover bolts and remove cover and driven plate from flywheel.

(24) Remove pilot bushing lubricating wick from bushing bore in crankshaft and soak wick in clean engine oil.

(25) Remove bolts attaching transfer case to transmission adapter housing and remove transfer case from transmission.

## CLUTCH INSTALLATION

(1) Install pilot bushing lubricating wick.

(2) Insert Clutch Alignment Tool J-5824-01 in driven plate hub and position plate on flywheel. Be sure alignment tool is fully seated in pilot bushing.

**NOTE:** Be sure the driven plate side marked flywheel side is positioned against the flywheel.

(3) Position clutch cover on flywheel and over driven plate.

(4) Align driven plate and clutch cover using alignment tool and install cover attaching bolts finger-tight only.

(5) Tighten clutch cover bolts alternately and evenly to 23 foot-pounds (31 N•m) torque.

**CAUTION:** To avoid warping the clutch cover, tighten the cover attaching bolts a few turns at a time only.

(6) Install clutch housing on engine and install housing attaching bolts. Tighten bolts to 54 foot-pounds (73 N•m) torque.

(7) Install throwout bearing in throwout lever. Center bearing over clutch cover release fingers.

(8) Shift transmission into gear using long handle screwdriver.

(9) Install transmission. Be sure to align transmission clutch shaft and driven plate splines before installation.

(10) Install and tighten transmission-to-clutch housing bolts to 54 foot-pounds (73 N•m) torque.

(11) Install transfer case on transmission. Raise transfer case using transmission jack. Align transmission output and transfer case input shaft splines by rotating output shaft yoke.

(12) Install and tighten transfer case attaching bolts to 30 foot-pounds (41 N•m) torque, and remove transmission jack.

(13) Position transfer case shift lever and shifter shaft. Install shaft retaining nut and tighten nut securely.

(14) Install transfer case shift control link assembly and install link retaining pins through links and shift rods. Use new cotter keys to retain link pins. Be sure shift lever is properly aligned in control link assembly.

(15) Connect vent hose to transfer case vent.

(16) Connect backup light switch and 4WD indicator switch wires.

(17) Connect speedometer cable to transfer case.

(18) Connect front and rear propeller shafts to transfer case yokes. Be sure to align shafts and yokes using assembly reference marks made previously. Tighten U-joint clamp strap bolts to 15 foot-pounds (20 N•m) torque.

(19) Install rear crossmember. Tighten crossmember attaching nuts to 30 foot-pounds (41 N•m) torque.

(20) Connect parking brake cable if cable was disconnected.

(21) Install slave cylinder on clutch housing. Be sure cylinder push rod is properly seated in throwout lever.

(22) Fill transfer case to correct level with specified lubricant. Refer to Chapter 2D.

(23) Remove stand used to support engine and lower vehicle.

(24) Install transmission shift lever assembly.

(25) Install screws attaching transmission shift lever boot to floorpan.

## PILOT BUSHING REPLACEMENT

### Removal

(1) Remove clutch assembly. Refer to Clutch Removal in this section.

(2) Obtain and lubricate replacement pilot bushing with engine oil.

(3) Remove pilot bushing lubricating wick and soak wick in engine oil.

(4) Remove old bushing using Tool J-5822 or, pack bushing bore with grease, insert clutch alignment tool into bushing, and tap tool with mallet. Hydraulic pressure of grease will force bushing out.

(5) Clean crankshaft bore if grease was used to remove old bushing.

### Installation

(1) Install pilot bushing lubricating wick in bushing bore in crankshaft.

(2) Install replacement pilot bushing in crankshaft bushing bore using Clutch Alignment Tool J-5824-01.

**CAUTION:** Do not allow the bushing to become cocked during installation. The bushing and installer tool must be kept parallel with the crankshaft centerline during installation.

(3) Remove bushing installer tool.

(4) Install clutch, transmission, and transfer case assemblies. Refer to Clutch Installation in this section.

## THROWOUT BEARING AND LEVER

### Removal

(1) Remove transmission-transfer case assembly. Refer to Clutch Removal in this section.

(2) Remove throwout lever boot.

(3) Disconnect throwout lever spring (fig. 2A-5).

(4) Remove throwout lever and bearing as assembly.

(5) Remove throwout bearing from lever.

### Installation

(1) Fill slots in inner groove of replacement throwout bearing with AMC/Jeep chassis lubricant, or equivalent.

(2) Position throwout lever on pivot ball in clutch housing and connect lever spring to lever.

(3) Install throwout lever boot.

(4) Install throwout bearing in lever. Be sure bearing retaining springs are engaged in lever.

(5) Install transmission-transfer case assembly. Refer to Clutch Installation in this section.

## FLYWHEEL REPLACEMENT

### Removal

(1) Remove clutch, transmission, and transfer case assemblies. Refer to Clutch Removal in this section.

(2) Remove bolts attaching flywheel to crankshaft flange and remove flywheel.

### Installation

(1) Mount flywheel on crankshaft flange and install attaching bolts finger-tight.

(2) Tighten flywheel attaching bolts alternately and evenly to 65 foot-pounds (88 N•m) torque.

(3) Clean surface of replacement flywheel with alcohol to remove all traces of oil, grease, or other protective substances.

(4) Install clutch, transmission, and transfer case assemblies. Refer to Clutch Installation in this section.

## TRANSMISSION CLUTCH SHAFT

If the transmission clutch shaft requires replacement, remove and disassemble the transmission and replace the shaft. Refer to Chapter 2B—Manual Transmission for the necessary service procedures.

## CLUTCH HOUSING ALIGNMENT

The clutch housing alignment procedure for four-cylinder CJ models is the same as for six-cylinder models without transmission adapters. Refer to Clutch Housing Alignment—Alignment Check without Transmission Adapter in the Six- and Eight-Cylinder Model Clutch service section.

## CLUTCH CYLINDER SERVICE

### Removal

(1) Disconnect hydraulic line at clutch cylinder (fig. 2A-8). Use flarenut wrench to loosen and remove fitting as fitting hex may be damaged by open end wrench.

(2) Cap hydraulic line and cylinder opening to prevent dirt entry.

(3) Remove cotter pin and washer that retain cylinder push rod on clutch pedal and slide rod off pedal pivot.

(4) Remove nuts attaching clutch cylinder to mounting studs on dash panel and remove cylinder.

### Disassembly

(1) Remove reservoir cap and rubber cover. Place cap and cover on clean, lint free paper or cloth.

**NOTE:** *It is not necessary to remove the rubber outer cover from the reservoir cap unless the cover is damaged.*

(2) Remove push rod dust cover. Use screwdriver to pry cover off cylinder. Discard cover after removal.

(3) Remove snap ring that retains push rod in cylinder. Use needlenose pliers to compress ends of snap ring and remove ring from cylinder bore. Discard snap ring after removal.

(4) Remove push rod, retaining washer and seal as assembly (fig. 2A-9). Remove and discard push rod seal.

(5) Remove plunger, valve spring, and valve stem assembly from cylinder bore (fig. 2A-9). Tap cylinder body lightly on wood block to dislodge assembly from bore.

(6) Compress valve spring slightly and pry tab of valve stem retainer upward to release retainer, spring, and stem assembly from plunger (fig. 2A-10).

**NOTE:** *The retainer tab is located in the rectangular slot in the side of the stem retainer (fig. 2A-10). Use a small, thin blade screwdriver to pry the tab upward.*

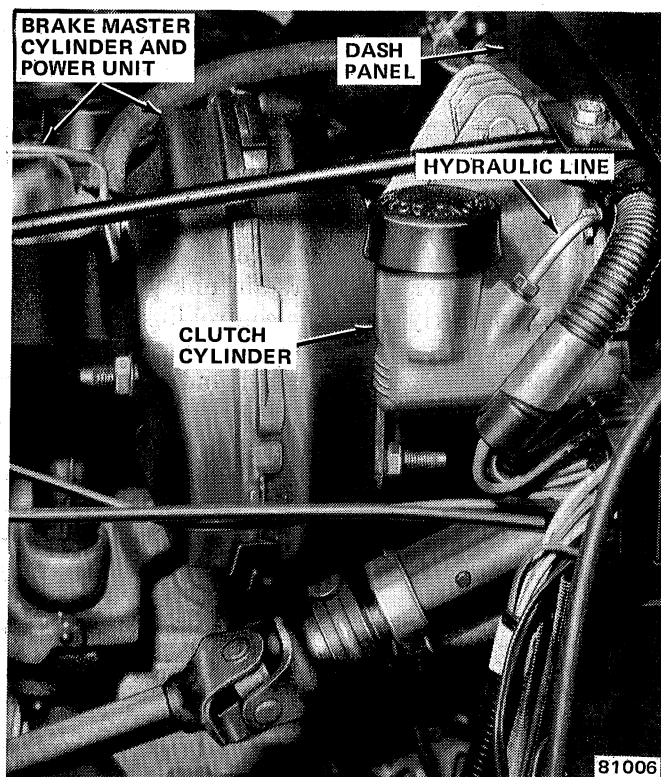

Fig. 2A-8 Clutch Cylinder Location

(7) Remove seal from plunger (fig. 2A-9). Discard seal after removal.

(8) Remove spring retainer and valve stem from valve spring.

(9) Remove valve stem from retainer and remove spring washer and stem tip seal from end of valve stem (fig. 2A-9). Discard stem tip seal and spring washer.

(10) Clean all parts thoroughly with brake fluid or brake cleaning solvent only.

(11) Inspect cylinder bore for cracks, porosity, wear, deep scoring or nicks, and severe corrosion or pitting. If bore exhibits any of these conditions, replace cylinder.

### Assembly

(1) Lubricate cylinder bore with brake fluid.

(2) Install replacement seals on plunger and valve stem. Be sure lip of plunger seal faces stem end of plunger. Also be sure stem tip seal is installed so that seal shoulder fits in undercut at end of valve stem.

(3) Install new spring washer on valve stem. Install plastic spring retainer on valve stem and over spring washer. Be sure large end of retainer is facing end of stem (fig. 2A-10).

(4) Install valve spring over stem and seat spring on stem retainer.

(5) Install assembled valve spring, retainer, and stem assembly on plunger (fig. 2A-10). Compress spring against plunger. When end of valve stem passes through

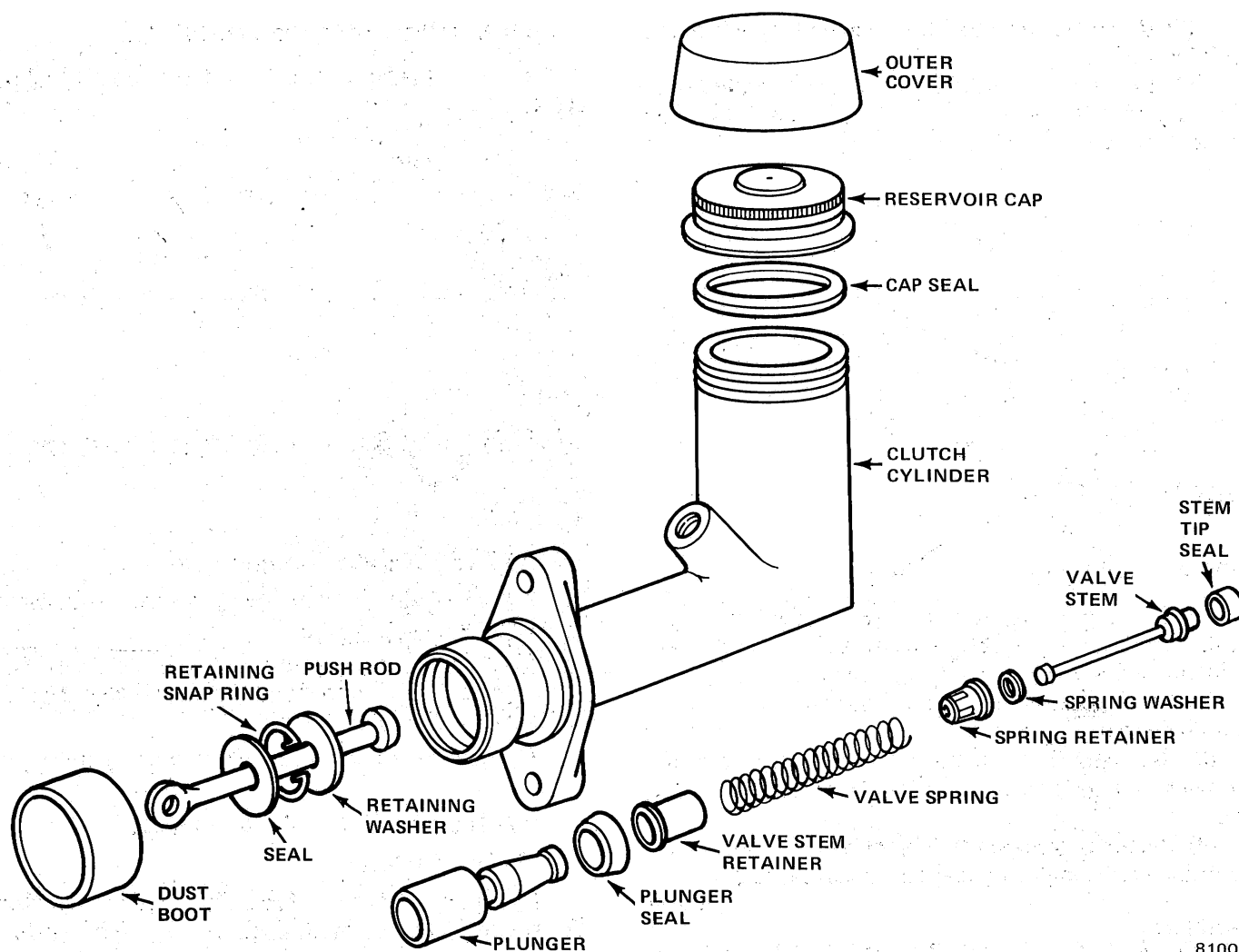

81007

Fig. 2A-9 Clutch Cylinder Assembly

stem retainer and seats in small bore in end of plunger, bend retainer tab downward to lock stem and retainer on plunger.

(6) Lubricate spring and plunger assembly with brake fluid and insert assembly (spring end first) into cylinder bore.

(7) Install new seal and dust cover on push rod.

(8) Lubricate ball-end of push rod, seal, and lip of dust cover with lubricant supplied in cylinder overhaul kit.

(9) Insert push rod and push rod retainer into cylinder bore. Secure push rod and retainer in bore using replacement snap ring supplied in overhaul kit.

(10) Slide push rod seal up against push rod retainer and install dust cover on end of cylinder. Be sure cover lip is seated in undercut on end of cylinder.

(11) Remove and discard old seal from filler cap and install new seal supplied in kit.

(12) Install rubber outer cover on filler cap, if removed.

## Installation

(1) Install clutch cylinder on dash panel mounting studs. Tighten cylinder attaching nuts to 11 foot-pounds (15 N•m) torque.

(2) Connect hydraulic line to clutch cylinder.

(3) Install cylinder push rod on clutch pedal pivot and install retaining washer and cotter pin.

(4) Fill clutch cylinder reservoir with brake fluid to level indicated on side of reservoir. Use AMC/Jeep brake fluid, or equivalent, marked SAE J-1703 or DOT 3 only to fill reservoir.

(5) Install reservoir cap and bleed clutch hydraulic system. Refer to Clutch Hydraulic System Bleeding.

## SLAVE CYLINDER SERVICE

### Removal

(1) Raise vehicle.

(2) Disconnect hydraulic line at cylinder.

(3) Remove throwout lever-to-cylinder push rod retaining spring.

(4) Remove bolts attaching cylinder to clutch housing and remove cylinder and heat shield, and throwout lever pivot, washer, and seal.

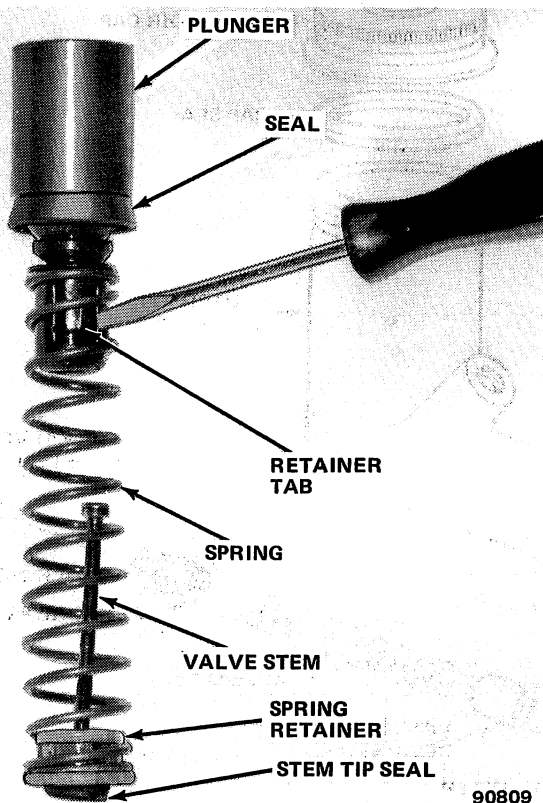

Fig. 2A-10 Removing Valve Spring and Stem from Plunger

**Disassembly**

- (1) Clean cylinder exterior thoroughly.
- (2) Remove boot from cylinder.
- (3) Remove cylinder push rod, boot, plunger and spring as assembly (fig. 2A-11).
- (4) Remove spring and seal from plunger.
- (5) Remove snap ring that retains push rod in plunger and remove push rod and boot.
- (6) Remove boot from push rod.
- (7) Clean parts with brake fluid.

**Assembly**

- (1) Install new boot on push rod.
- (2) Install push rod in plunger and install new push rod retaining snap ring.
- (3) Install spring on plunger.
- (4) Lubricate cylinder bore and seal with brake fluid.
- (5) Install assembled plunger, spring and push rod in cylinder.

(6) Install and secure boot on cylinder.

(7) Install pivot, washer and seal on end of push rod.

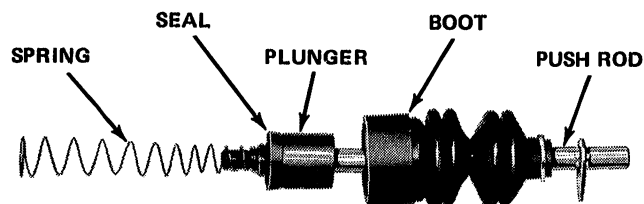

Fig. 2A-11 Slave Cylinder Push Rod, Plunger, and Spring Assembly

**Installation**

- (1) Position heat shield on cylinder.
- (2) Lubricate throwout lever socket with chassis lubricant.
- (3) Align push rod with throwout lever, position cylinder on clutch housing and install cylinder attaching bolts. Tighten bolts securely.
- (4) Connect throwout lever spring to cylinder push rod.
- (5) Connect hydraulic line to cylinder.
- (6) Lower vehicle.
- (7) Fill reservoir with brake fluid and bleed hydraulic system. Refer to Clutch Hydraulic System Bleeding.

**CLUTCH HYDRAULIC SYSTEM BLEEDING**

- (1) Fill reservoir with brake fluid.
- (2) Raise vehicle.
- (3) Compress slave cylinder plunger by pushing throwout lever forward as far as possible.
- (4) Attach one end of rubber hose to slave cylinder bleed screw. Place opposite end of hose in glass container 1/2 full of brake fluid. Be sure hose end is submerged in fluid.
- (5) Loosen bleed screw and hold throwout lever forward.
- (6) Have helper press and hold clutch pedal to floor. Tighten bleed screw and release pedal. Repeat bleeding operation until fluid entering container is free of bubbles.

**NOTE:** Do not allow the reservoir to run out of fluid during the bleeding operation.

- (7) Lower vehicle.
- (8) Adjust reservoir fluid level to level indicated on reservoir after completing bleeding operations.

**SPECIFICATIONS**

**Torque Specifications**

Service Set-To Torques should be used when assembling components. Service In-Use Recheck Torques should be used for checking a pre-tightened item.

	USA (ft.-lbs)		Metric (N·m)	
	Service Set-To Torque	In-Use Recheck Torque	Service Set-To Torque	In-Use Recheck Torque
Clutch Cover Bolts:				
Four-Cylinder .....	23	20-26	31	27-35
Clutch Housing-to-Engine Bolts:				
Four-Cylinder — All .....	54	46-62	73	62-84
Clutch Housing-to-Transmission Bolts:				
Four-Cylinder .....	54	46-62	73	62-84
Starter Motor-to-Clutch Housing Bolts:				
Four-Cylinder .....	54	46-62	73	62-84
Clutch Housing Inspection Cover Screws:				
Four-Cylinder .....	30	25-35	41	34-47
Flywheel-to-Crankshaft Bolts:				
Four-Cylinder .....	65	59-71	88	80-96
Rear Crossmember Stud Nuts:				
Four-Cylinder .....	35	30-40	47	41-54
Transmission Support Cushion-to-Crossmember Bolts:				
Four-Cylinder .....	25	20-30	34	27-41

All Torque values given in foot-pounds and newton-meters with dry fits unless otherwise specified.

80072B

**CLUTCH SERVICE —  
SIX- AND EIGHT-  
CYLINDER MODELS**

	<b>Page</b>
Clutch Cover Release Lever Adjustment	2A-19
Clutch Housing Alignment	2A-17
Clutch Inspection and Service	2A-16
Clutch Installation	2A-16
Clutch Pedal Replacement—CJ-Scrambler Models	2A-19

	<b>Page</b>
Clutch Pedal and Overcenter Spring Replacement— Cherokee-Wagoner-Truck	2A-20
Clutch Removal	2A-15
Specifications	2A-21

**CLUTCH REMOVAL**

- (1) Remove transmission as outlined in Chapter 2B.
- (2) Remove starter motor.
- (3) Remove throwout bearing.
- (4) Remove clutch housing.
- (5) Mark position of clutch cover on flywheel for assembly alignment reference.

- (6) Loosen clutch cover attaching bolts one or two turns at a time and in rotation to relieve spring tension on cover.

**CAUTION:** The clutch cover bolts must be loosened evenly and in rotation to avoid cover distortion. The cover is a steel stamping and could be warped if improperly removed resulting in clutch chatter when installed.

(7) Remove clutch cover bolts and remove cover and driven plate from flywheel.

**NOTE:** *Observe which side of the driven plate faces the flywheel before removing the plate. Paint or chalk alignment marks on the plate for assembly reference.*

(8) Remove pilot bushing lubricating wick and soak wick in engine oil.

(9) Inspect and service clutch components as outlined under Clutch Component Inspection.

## CLUTCH INSTALLATION

(1) Check and correct clutch cover release lever height if necessary. Lubricate release lever pivots sparingly. Do not over lubricate pivots.

(2) Install pilot bushing lubricating wick in crankshaft bore.

(3) Insert Clutch Alignment Tool J-5824-01 (Cherokee, Wagoneer and Truck), Alignment Tool J-5824-01 (CJ and Scrambler), or spare clutch shaft in driven plate hub and mount assembled plate and tool on flywheel. Be sure alignment tool is fully seated in pilot bushing.

**CAUTION:** *Be sure the correct side of the driven plate faces the flywheel. Refer to the reference marks placed on the driven plate during clutch removal.*

(4) Position clutch cover on flywheel and over driven plate and alignment tool. Align cover and flywheel according to reference marks made during clutch removal and install cover attaching bolts finger-tight only.

(5) Tighten cover attaching bolts alternately and evenly to 40 foot-pounds (54 N•m) torque. Be sure to maintain cover-to-plate alignment while tightening bolts.

**CAUTION:** *The cover attaching bolts must be tightened alternately and evenly to avoid distorting the cover.*

(6) Install clutch housing and tighten housing attaching bolts to specified torque. Refer to Specifications.

(7) Install starter motor.

(8) Install throwout bearing. On CJ and Scrambler models, be sure bearing tension springs are engaged in throwout lever.

(9) Install transmission as outlined in Chapter 2B.

## CLUTCH INSPECTION AND SERVICE

### Driven Plate

Inspect the friction material for excessive wear, or charred, cracked, broken or loose friction material.

Check the driven plate steel hub and cushion springs for distortion, cracks, or breakage. Replace the driven plate if it exhibits any of these conditions.

**NOTE:** *Do not replace the driven plate if the cushion springs only appear loose. This is a normal condition when the plate is removed from the vehicle and the springs are not under load.*

### Clutch Cover

Inspect the cover for cracks, distortion, broken or collapsed apply springs and for broken, bent, loose, or excessively worn release levers. Inspect the pressure plate surface for deep scores, cracks, heat checking or discoloration, and for evidence of warping (use a straightedge to check pressure plate surface flatness). Replace the cover as an assembly if it exhibits any of these conditions.

**NOTE:** *The centrifugal rollers in the clutch cover may rattle when the cover is removed and not under load. Do not replace the cover if this occurs, it is a normal condition.*

### Throwout Bearing

A simple throwout bearing design is used on Jeep vehicles. The bearing is retained on the throwout lever by tension springs.

**CAUTION:** *The throwout bearings used on Jeep vehicles are permanently lubricated during manufacture. Do not wash or immerse the bearings in solvent as the bearing lubricant could be dissolved. Clean the bearing by wiping it with shop towels.*

Inspect the bearing for excessive wear and deep scoring on the release lever contact surface, looseness on the sleeve, or discoloration which indicates overheating. Check the sleeve bore for excessive wear or burrs which could cause it to bind on the front bearing cap. Rotate the bearing on the sleeve. The bearing must rotate freely and not bind. When rotating the bearing, also listen for grinding or grating sounds which indicate that the internal rollers are worn or damaged. Check the bearing tension springs for distortion or breakage. Replace the bearing if it exhibits any of these conditions.

### Transmission Front Bearing Cap

Inspect the bearing cap for deep scoring or excessive wear. Replace the bearing cap if worn or scored and inspect the throwout bearing sleeve for burrs, wear or other damage which could cause a bind condition. Replace the bearing cap or throwout bearing if either exhibits these conditions.



## Crankshaft Pilot Bushing

Inspect the bushing for excessive wear, deep scoring, cracks, or looseness. Replace the bushing if worn or damaged.

### Bushing Replacement

- (1) Obtain replacement bushing and soak bushing in engine oil.
- (2) Remove bushing lubricating wick.
- (3) Fill crankshaft bore and pilot bushing with chassis grease.
- (4) Insert clutch aligning tool into bushing and tap end of tool with lead hammer. Hydraulic pressure generated by compressed grease will force bushing out of crankshaft bore.

**NOTE:** If the bushing proves difficult to remove using the hydraulic method, remove the bushing using Puller Tool J-5822 and Slide Hammer J-2619-01.

- (5) Remove all grease from crankshaft bore and clean bore thoroughly.
- (6) Install replacement pilot bushing on Clutch Alignment Tool J-5824-01.
- (7) Install bushing in crankshaft bore using clutch alignment tool as bushing driver. Keep bushing straight during installation and be sure it is fully seated.
- (8) Install bushing lubricating wick.

## Flywheel

Inspect the flywheel surfaces for cracks, deep scoring, excessive wear, heat checking, discoloration, and excessive face runout or distortion. Check face runout using a dial indicator. Runout must not exceed 0.005 inch (0.12 mm) with the crankshaft end play held to zero. Use a straightedge to check surface flatness. Inspect the ring gear teeth for cracks, breakage, or excessive wear. If the ring gear teeth are severely milled (worn), also check the starter motor drive teeth for similar wear or damage. Check the flywheel attaching bolt torque and tighten the bolts to 105 foot-pounds (142 N•m) torque if necessary. Replace the flywheel if it exhibits any of the conditions just described.

## Transmission Clutch Shaft

Install the driven plate on the clutch shaft. The driven plate must move freely on the shaft splines. If the splines have burrs, remove them using a file or oilstone. If the driven plate does not move freely on the splines, incomplete clutch release will occur resulting in hard shifting. Replace the clutch shaft if worn or damaged. Refer to Chapter 2B for procedure.

## CLUTCH HOUSING ALIGNMENT

Clutch housing misalignment is caused by excessive face or bore runout of the clutch housing or housing-to-transmission adapter. Misalignment will cause improper clutch release, driven plate failure, front transmission bearing failure, premature crankshaft pilot bushing wear, and clutch noise and vibration. In severe cases, misalignment will also cause gear jump-out on deceleration. If these malfunctions occur, the rear face and bore of the clutch housing or housing-to-transmission adapter must be checked for excessive runout.

### Alignment Check—Without Transmission Adapter

**NOTE:** Use the following procedure when the vehicle is not equipped with a clutch housing-to-transmission adapter.

- (1) Remove transmission as outlined in Chapter 2B.
- (2) Remove clutch housing, clutch cover, and driven plate.
- (3) Remove one flywheel attaching bolt.
- (4) Obtain 1/2-20 x 9-inch bolt and 1/2-20 nut for use as dial indicator support.
- (5) Thread nut onto bolt until 10 or 12 bolt threads are exposed.
- (6) Thread bolt into crankshaft attaching bolt hole and tighten nut to secure bolt.
- (7) Install clutch housing on engine and tighten housing attaching bolts to specified torque. Refer to Specifications.
- (8) Mount dial indicator on 9-inch bolt. Indicator stylus must contact rear face of clutch housing approximately 1/8 inch from edge of bore (fig. 2A-12).
- (9) Rotate crankshaft and check face runout of housing. Face runout must not exceed 0.010 inch (0.25 mm) total indicator reading at any point throughout 360 degrees rotation.

**NOTE:** Crankshaft end play must be held to zero to obtain an accurate face runout reading. Move and hold the crankshaft forward or rearward using a pry bar to remove end play.

- (10) If face runout is over specified limits, correct runout as follows:
  - (a) Move dial indicator aside and loosen clutch housing attaching bolts.
  - (b) Insert shims between housing and engine-to-housing spacer as required to correct runout (fig. 2A-13). Install shims at points A to align top of housing with bottom of housing. Install shims at points B, D, C, or E to correct runout at either side of clutch housing. Shims installed at points D and E will also align housing from bottom to top.
  - (c) Tighten housing attaching bolts to specified torque.

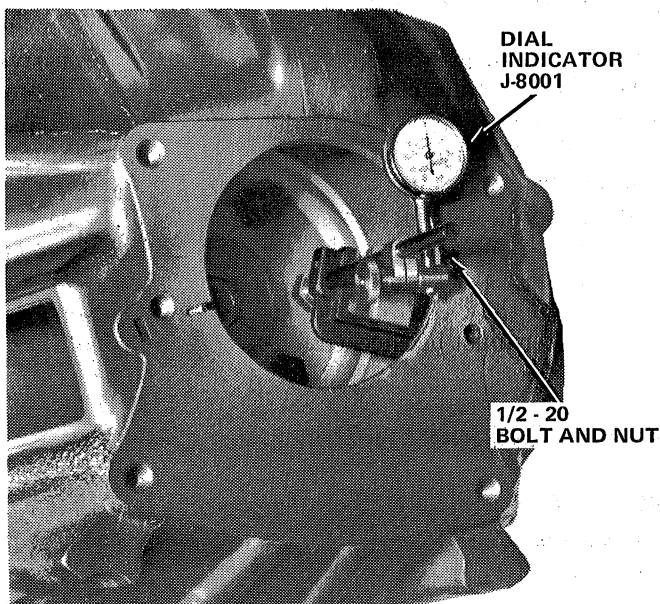
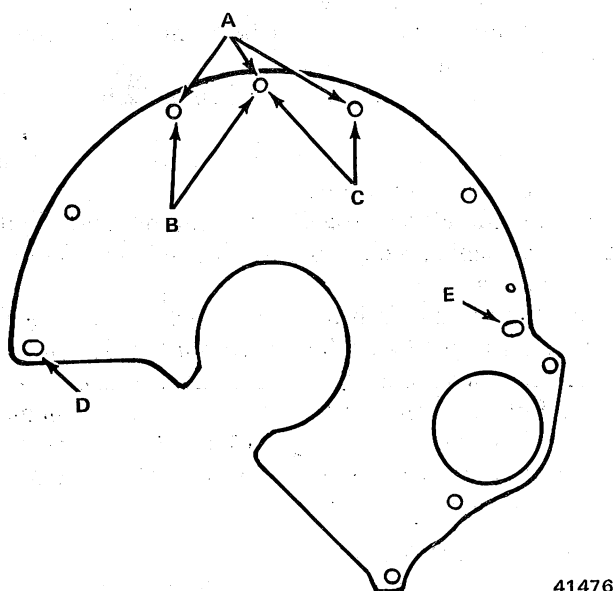

Fig. 2A-12 Mounting Dial Indicator



41476

Fig. 2A-13 Shim Placement (Six-Cylinder Engine Shown)

(d) Reposition dial indicator stylus on housing face and recheck face runout.

(e) Total face runout of clutch housing must not exceed 0.010 inch (0.25 mm). Relocate shims as necessary to correct runout.

(11) Check clutch housing bore alignment by positioning dial indicator stylus on inside diameter of housing bore.

(12) Hold crankshaft end play to zero, rotate crankshaft and note dial indicator reading at four equally spaced points. Bore runout must not exceed 0.010 inch (0.25 mm) total indicator reading at any point.

**NOTE:** Any change in face alignment will also change bore alignment. In some cases, it is possible to correct bore alignment simply by correcting face alignment. Where it is impossible to correct bore alignment to a maximum of 0.010 inch (0.25 mm) runout (after changing face alignment), replace the clutch housing.

### Alignment Check—With Transmission Adapter

Use the following procedure to check clutch housing-to-transmission adapter alignment.

- (1) Remove transmission as outlined in Chapter 2B.
- (2) Remove clutch housing and adapter as assembled. Do not remove adapter from housing.
- (3) Remove clutch cover and driven plate.
- (4) Remove one flywheel attaching bolt.
- (5) Obtain 1/2-20 x 15-inch bolt and 1/2-20 nut for use as dial indicator support.
- (6) Thread nut onto bolt until 10 to 12 threads are exposed.
- (7) Thread bolt into flywheel attaching bolt hole and tighten nut to secure bolt.
- (8) Install clutch housing and adapter assembly and tighten housing bolts to specified torque.
- (9) Mount dial indicator on bolt. Position indicator so stylus contacts transmission mating face of adapter about 1/8 inch from edge of adapter bore.
- (10) Zero dial indicator, rotate crankshaft 360 degrees, and observe adapter face runout. Runout must not exceed 0.010 inch (0.25 mm) total indicator reading at any point through 360 degrees of rotation.

**CAUTION:** Crankshaft end play must be held to zero to obtain an accurate face runout reading. Move and hold the crankshaft forward or rearward using a pry bar to eliminate end play.

(11) Check bore runout of adapter. Position dial indicator so stylus contacts adapter bore at approximate center of bore.

(12) Zero dial indicator, rotate crankshaft 360 degrees, and observe runout of adapter bore. Runout must not exceed 0.010 inch (0.25 mm) at any point through 360 degrees of rotation.

**NOTE:** Crankshaft end play must be held to zero to obtain an accurate runout reading. Move and hold the crankshaft forward or rearward using a pry bar to eliminate end play.

(13) If adapter runout is above specified limits, correct adapter misalignment as outlined in following steps.

(14) If adapter bore runout is within limits but out of tolerance at face, shim clutch housing as required to obtain runout of 0.010 inch (0.25 mm) or less. Shim housing as outlined under Alignment Check—Without Transmission Adapter.

(15) If adapter face runout is within limits but out of tolerance at bore, proceed as follows:

(a) Loosen adapter-to-clutch housing bolts one or two turns.

(b) Move adapter up, down, or side-to-side as required to obtain runout of 0.010 inch (0.25 mm) or less. Tap adapter with hammer to reposition it.

(c) When runout is corrected, tighten adapter bolts to 35 foot-pounds (47 N•m) torque.

(d) Recheck runout and adjust adapter position again if necessary.

(16) If adapter face or bore runout cannot be brought within tolerance, replace adapter and clutch housing.

(17) If adapter and housing are replaced, install dial indicator and check runout of replacement parts.

(18) After checking and correcting adapter alignment, remove dial indicator and remove clutch housing with adapter attached. Do not remove adapter or disturb adapter position if runout was corrected.

**CAUTION:** If the clutch housing was shimmed, mark the location of the shims for assembly reference before removing the housing.

(19) Remove 1/2-20 bolt and nut from flywheel and install flywheel bolt removed previously. Tighten bolt to 105 foot-pounds (142 N•m) torque.

(20) Install driven plate and clutch cover. Tighten clutch cover bolts to 40 foot-pounds (54 N•m) torque.

(21) Install clutch housing and adapter assembly and clutch housing alignment shims as necessary.

(22) Tighten clutch housing bolts to specified torque. Refer to Specifications.

(23) Install transmission as outlined in Chapter 2B.

## CLUTCH COVER RELEASE LEVER ADJUSTMENT

**NOTE:** Always check and correct the release lever height adjustment, if necessary, before installing an original or replacement clutch cover.

(1) Install Gauge Plate Tool J-1048, on flywheel in position normally occupied by driven plate (fig. 2A-14).

(2) Position clutch cover over gauge plate. Cover release levers must be directly over machined lands of gauge plate and gauge plate hub must be centered between ends of release levers.

(3) Install clutch cover on flywheel. Tighten cover attaching bolts in rotation, one or two turns at a time to avoid distorting cover.

(4) Compress each release lever several times to seat levers in operating position (fig. 2A-15). Use hammer handle to compress levers.

(5) Measure height of each lever relative to gauge hub using Clutch Lever Height Gauge Tool J-23330 (fig. 2A-16). Gauge tool has four different dimensional settings which can be used for measuring above and below hub.

(6) Adjust release levers by turning lever height adjusting nuts until lever is at desired height.

(7) After each lever has been adjusted, work lever down and up several times and recheck adjustment. If adjustment is correct, stake nut with punch to secure it.

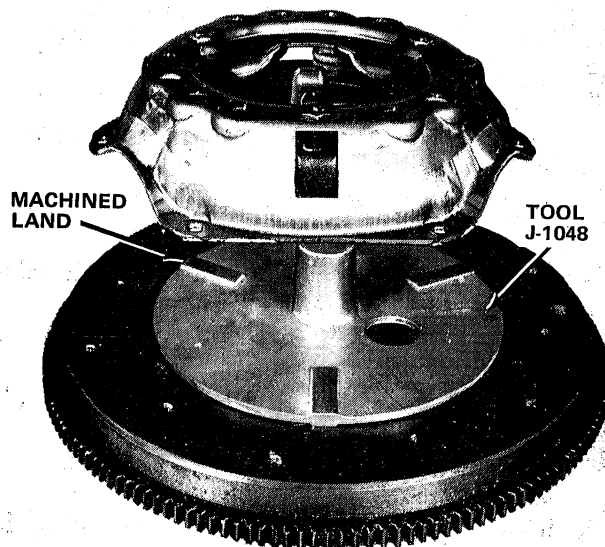

Fig. 2A-14 Mounting Gauge Plate J-1048

41513

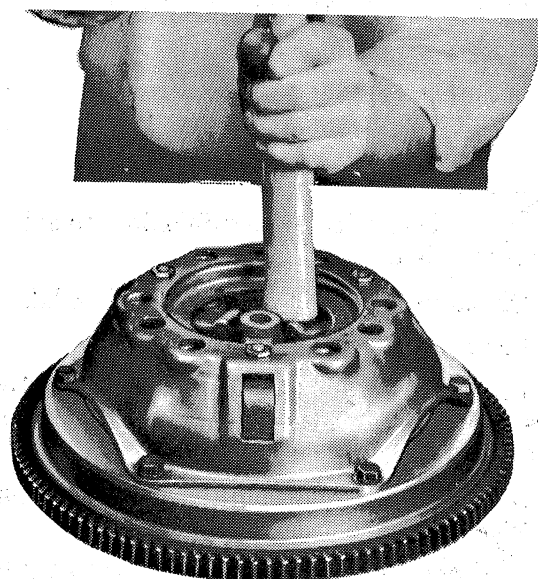

Fig. 2A-15 Compressing and Seating Release Levers

42575

## CLUTCH PEDAL REPLACEMENT—CJ AND SCRAMBLER MODELS

(1) Disconnect battery negative cable.

(2) Remove snap ring on end of pedal shaft and remove clutch pedal.

(3) Disconnect clutch pedal push rod from clutch pedal and remove clutch pedal.

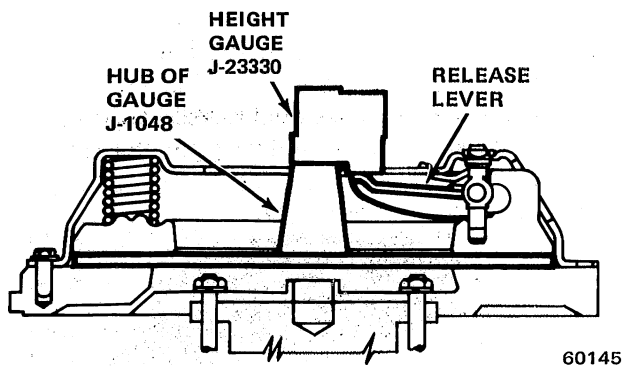

Fig. 2A-16 Measuring Release Lever Height

- (4) Lubricate bushings in replacement clutch pedal with Lubriplate, or equivalent lubricant.
- (5) Connect clutch pedal push rod to replacement clutch pedal.
- (6) Install clutch pedal on pedal shaft and install snap ring on end of shaft.
- (7) Connect clutch pedal push rod to bellcrank.
- (8) Connect battery negative cable.
- (9) Check and adjust clutch pedal free play, if necessary.

### CLUTCH PEDAL AND OVERCENTER SPRING REPLACEMENT—CHEROKEE-WAGONEER-TRUCK

#### Overcenter Spring

##### Removal

- (1) On vehicles with air conditioning, remove left side duct extension.
- (2) Disconnect clutch push rod at clutch pedal.
- (3) Remove clutch pedal stop.
- (4) Press clutch pedal halfway down to spread overcenter spring coils slightly and insert thin shims between overcenter spring coils.
- (5) Raise clutch pedal until pedal stops against lower edge of instrument panel.
- (6) Disconnect and remove overcenter spring from pedal and support bracket.

##### Installation

- (1) Insert thin shims between overcenter spring coils.
- (2) Install overcenter spring on support bracket and clutch pedal.
- (3) Remove shims from overcenter spring coils.
- (4) Connect clutch push rod to clutch pedal.

- (5) Install clutch pedal stop.
- (6) Check clutch release rod position. Be sure rod has not become disengaged from throwout lever.
- (7) Check and adjust clutch pedal free play, if necessary.

#### Clutch Pedal

##### Removal

- (1) Disconnect battery negative cable.
- (2) Remove bolt attaching engine compartment wiring harness to dash panel connector.
- (3) Disconnect engine compartment wiring harness out of dash panel connector.
- (4) On vehicles with air conditioning, remove left side duct extension.
- (5) Disconnect clutch push rod at clutch pedal.
- (6) Remove clutch pedal stop.
- (7) Remove overcenter spring. Refer to Clutch Pedal Overcenter Spring Replacement—Cherokee-Wagoneer-Truck.
- (8) Remove fuse panel attaching screws and remove fuse panel.
- (9) Remove snap ring from clutch pedal end of pedal shaft using snap ring pliers with 90 degree tips.
- (10) Remove clutch pedal from pedal shaft.

##### Installation

- (1) Install clutch pedal on pedal shaft.
- (2) Install retaining snap ring on clutch pedal end of pedal shaft. Be sure ring is fully seated.
- (3) Install fuse panel.
- (4) Install overcenter spring. Refer to Clutch Pedal Overcenter Spring Replacement—Cherokee-Wagoneer-Truck.
- (5) Install clutch pedal stop.
- (6) Connect clutch push rod to clutch pedal.
- (7) On vehicles with air conditioning, install left side duct extension.
- (8) Connect engine compartment wiring harness to dash panel connector and install connector attaching screw.
- (9) Install battery negative cable.
- (10) Check and adjust clutch pedal free play, if necessary.

**SPECIFICATIONS**

**Clutch Specifications**

Model	Engine (CID)	Clutch Diameter	Release Lever Height (Above Gauge Hub)	Pedal Free Play
CJ-5/CJ-7 Scrambler	151	9-1/8 (23.5 cm)	1.595 to 1.720 (40.5 to 43.7 mm)	N/A
	258*	10-1/2 in. (26.7 cm)	2.04 to 2.16 (51.8 to 68.6 mm)	1 to 1-1/4 in. (25.4 to 31.7 mm)
Cherokee, Wagoneer, Truck	258*	10-1/2 in. (26.7 cm)		1 to 1-1/4 in. (25.4 to 31.7 mm)
	360	11 (27.9 cm)	3/16 (4.7 mm)	3/8 to 5/8 (9.5 to 15.8 mm)

\*With .305 Gauge

60567

**Clutch Housing Alignment Specifications**

- Clutch Housing Bore to Crankshaft Centerline . . . 0.010 max. (0.25 mm)
- Clutch Housing Transmission Mounting Face to Crankshaft Centerline . . . . . 0.010 max. (0.25 mm)
- Clutch Housing to Transmission Adapter Bore to Crankshaft Centerline . . . . . 0.010 max. (0.25 mm)
- Clutch Housing to Transmission Adapter Face to Crankshaft Centerline . . . . . 0.010 max. (0.25 mm)
- Flywheel Runout at Face . . . . . 0.005 max. (0.12 mm)

60569

**Torque Specifications**

Service Set-To Torques should be used when assembling components. Service In-Use Recheck Torques should be used for checking a pre-tightened item.

	USA (ft-lbs)		Metric (N·m)	
	Service Set-To Torque	In-Use Recheck Torque	Service Set-To Torque	In-Use Recheck Torque
Clutch Bellcrank Bracket to Frame Rail Bolt (Cke., Wag., Trk.) . . . . .	14	12-16	19	16-22
Clutch Bellcrank Pivot . . . . .	35	30-40	47	41-54
Clutch Housing Inspection Cover Screws:				
Four-Cylinder . . . . .	30	25-35	41	34-47
Clutch Housing Spacer to Block Bolt (Eight-Cylinder Engines) . . . . .	15	12-17	20	16-23
Clutch Housing to Engine Block Bolt				
Six-Cylinder Engines				
Top . . . . .	35	30-40	47	41-54
Bottom . . . . .	45	40-50	61	54-68
Eight-Cylinder Engines				
Top . . . . .	30	25-35	41	34-47
Bottom . . . . .	30	25-35	41	34-47
Clutch Housing-to-Engine Bolts:				
Four-Cylinder — All . . . . .	54	46-62	73	62-84
Clutch Housing to Engine Dowel Bolt Nut (6- and 8-Cylinder) . . . . .	45	40-50	61	54-68
Clutch Housing-to-Transmission Bolts:				
Four-Cylinder . . . . .	54	46-62	73	62-84
Clutch, Hydraulic Fluid Line Fitting to Master Cylinder . . . . .		132 in-lbs		120-144 in-lbs
Clutch, Hydraulic Fluid Line Fitting to Slave Cylinder . . . . .		190 in-lbs		160-220 in-lbs
Clutch Pedal Rebound Bumper, Bolt, Nut, and Lockwasher Assembly to Pedal . . . . .	40	35-45	54	47-61
Clutch Pedal Shaft Locknut . . . . .	33	30-36	45	41-49
Flywheel-to-Crankshaft Bolts:				
Four-Cylinder . . . . .	65	59-71	88	80-96
Rear Crossmember Stud Nuts:				
Four-Cylinder . . . . .	35	30-40	47	41-54
Starter Motor-to-Clutch Housing Bolt:				
Four-Cylinder . . . . .	54	46-62	73	62-84
Six- and Eight-Cylinder . . . . .	18	12-25	24	16-34
Transmission Case to Clutch Housing Bolt . . . . .	55	50-60	74	68-81
Transmission Support Cushion-to-Crossmember Bolt:				
Four-Cylinder . . . . .	25	20-30	34	27-41

All Torque values given in foot-pounds and newton-meters with dry fits unless otherwise specified. Refer to Standard Torque Specifications and Capscrew Markings Chart in Section A of this manual for any torque specifications not listed above.

60568

Tools

J-1048  
CLUTCH  
GAUGE  
PLATE

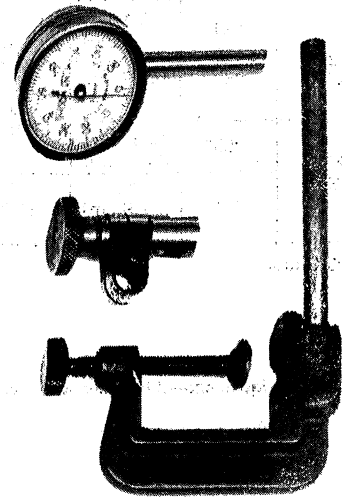
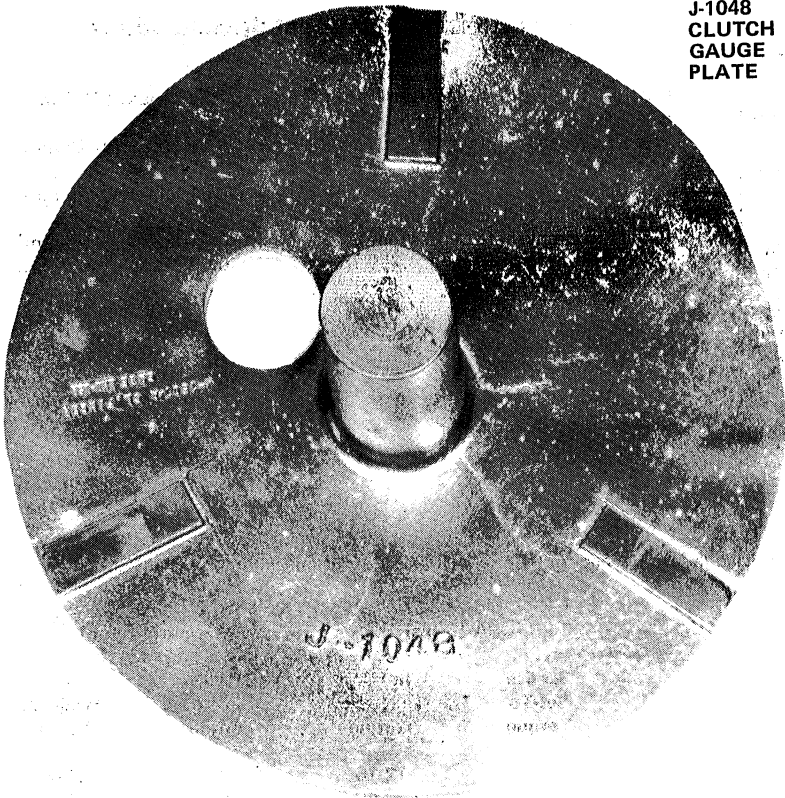

J-8001  
DIAL  
INDICATOR  
SET



J-5824-01  
ALIGNING  
TOOL

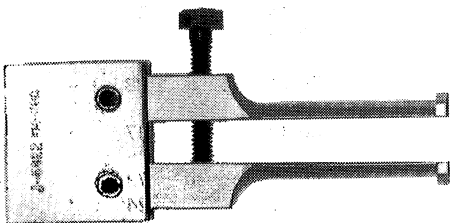

REMOVER TOOL  
J-5822



SLIDE HAMMER  
J-2619-01

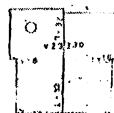

J-23330  
CLUTCH LEVER  
HEIGHT GAUGE